

A REFINED NONLINEAR MODEL OF COMPOSITE PLATES WITH INTEGRATED PIEZOELECTRIC ACTUATORS AND SENSORS

PERNGJIN F. PAI, ALI H. NAYFEH, KYOYUL OH and DEAN T. MOOK
Department of Engineering Science and Mechanics, Virginia Polytechnic Institute and State University, Blacksburg, VA 24061, U.S.A.

(Received 8 April 1992; in revised form 21 October 1992)

Abstract—A fully nonlinear theory for the dynamics and active control of elastic laminated plates with integrated piezoelectric actuators and sensors undergoing large-rotation and small-strain vibrations is presented. The theory fully accounts for geometric nonlinearities (large rotations and displacements) by using local stress and strain measures and an exact coordinate transformation. Moreover, the model accounts for continuity of interlaminar shear stresses, extensionality, orthotropic properties of piezoelectric actuators, dependence of piezoelectric strain constants on induced strains, and arbitrary orientations of the integrated actuators and sensors. Extension and shearing forces and bending and twisting moments are introduced onto the plate along the boundaries of the piezoelectric actuators. Five nonlinear partial differential equations describing the extension-extension-bending-shear-shear vibrations of laminated plates are obtained, which display linear elastic and nonlinear geometric couplings among all motions. Piezoelectric actuator-induced warping is also addressed, and comparisons with other simplified models and nonlinear theories are made.

1. INTRODUCTION

The post-buckling strength of thin plates plays an important role in the design of aircraft structures because conventional aircraft structural elements are often designed to operate in the post-buckling range. Hence, nonlinear problems considered in the theory of linearly elastic plates were mostly those of post-buckling analysis, prediction of stability, and nonlinear panel flutter analysis. In recent years, the rapid developments in aerospace exploration have stimulated extensive research into the dynamics and control of flexible structures. Because flexible structures have low flexural rigidity and usually have small material damping and because there is no air damping in space, fast maneuvers often lead to destructive large-amplitude vibrations, which introduce excessive material fatigue and affect their operational accuracy. Thus, it is desirable to control and stabilize a space system during and/or after any maneuver. To identify system characteristics and design strategies for the control of large-amplitude plate vibrations, one needs to study the effect of geometric nonlinearities and understand the nonlinear dynamic behavior of plates. This requires an accurate nonlinear modeling of the plate and its accompanying control devices.

Active control can be used to achieve high damping factors and hence it is an effective way of controlling low-frequency vibrations of flexible structures without the disadvantages of passive control systems, such as heavy weight and large size. Active control systems can be divided into point sensor/actuator systems and distributed sensor/actuator systems. Point sensors and actuators require elastic supports, have large volume, and are relatively heavy compared with the weights of flexible structures, and hence they significantly alter the static and dynamic characteristics of such structures. Moreover, in a point sensor/actuator system a large number of sensors are needed to reveal the system response, and hence the on-board real time computation requirements are serious. Consequently, the so-called adaptive (or intelligent) structures, which are structural systems with integrated distributed actuators and/or sensors, provide an exciting new approach. Distributed sensor-actuator systems transfer the on-board real time computation efforts to the sensor design processes and reduce or even eliminate the requirements for signal processing. Moreover, some known characteristics of the system can be integrated into the sensor-actuator design process. Piezoelectric materials are commonly used in the design of such distributed sensor-actuator systems.

Lead zirconate titanate (PZT) and polyvinylidene fluoride (PVDF or PVF₂) are the most commonly used piezoelectric materials in structural control. They have similar electromechanical coupling effects (Jaffe *et al.*, 1971; Sessler, 1981). Applications of piezoelectric actuators and sensors in structural control include attaining control authority of an aerodynamic body by altering the twist curvature and camber of its aeroelastic lifting surfaces (Crawley *et al.*, 1988), altering the shape of an optical surface to attain a range of desired mirror curvatures and hence to quickly and accurately change the focal length or pointing direction of the mirror (Chiarappa and Claysmith, 1981), actively controlling the borne noise of structures (Atluri and Amos, 1988; Clark and Fuller, 1990; Wang *et al.*, 1991), etc. Moreover, piezoelectric actuators can be used to greatly enhance the control of advanced composite structures with inherent elastic couplings and directional stiffnesses.

PZT is the most researched and used piezoelectric material in the control of structures, but it is brittle and difficult to fabricate into complex shapes and large sheets of films. On the other hand, the new material PVDF is characterized by such properties as flexibility, light weight and inexpensiveness. PVDF materials are available in large sheets of thin films and easy to shape into specific geometries to implement modal actuators and modal sensors for the control and sensing of flexible structures (Lee, 1990). Furthermore, PVDF materials have a large range of dynamic sensitivity, and their maximum response frequency is in the GHz range. All these qualities have made PVDF very attractive for adaptive vibration control of structural systems.

To date, models of induced strain actuator/substrate systems are very limited because most of the researchers concentrated their efforts on the implementation of control algorithms. Most of the models in the literature [e.g. Lee (1990), Lazarus and Crawley (1989), Lee and Moon (1989), Im and Atluri (1989) and Tzou and Gadre (1989)] are based on the Kirchhoff hypothesis and hence neglect transverse shear deformations. However, shear effects are significant for composite plates because the ratios of the inplane Young's moduli E_x ($x = 1, 2$) to the transverse shear moduli G_{xz} are between 20 and 50 in modern composites and between 2.5 and 3.0 in isotropic materials. There are several refined shear-deformable plate theories with the third-order shear theory (Reddy, 1984; Bhimaraddi and Stevens, 1984) being the most recommended theory. But most of the shear deformation theories, including the third-order theory, do not account for the continuity of interlaminar shear stresses and the elastic coupling between two transverse shear deformations. In the present formulation, we extend the piecewise linear displacement field used by Di Sciuva (1987) and Librescu and Schmidt (1991) by using quadratic and cubic interpolation functions to satisfy continuity of interlaminar shear stresses, to accommodate free shear-stress conditions on the bounding surfaces, and to account for nonuniform distributions of transverse shear stresses in each layer.

Geometric nonlinearities are either totally ignored or considered in an incomplete manner in most of the existing models. Geometric nonlinearities introduce nonlinear dynamic responses, such as flutter and chaotic vibrations, into a plate system under steady external excitations. Furthermore, in a nonlinear system an unstable "steady" solution with small amplitude can be sustained for a long time before it diverges, and hence it may be mistaken for a linear stable solution (Fujino *et al.*, 1990). Although the motion of a structure subject to control actions is a transient vibration, Balachandran *et al.* (1992) showed that modal interactions can produce small-amplitude transient vibrations in nonlinear systems, which pose difficulties in their identification using linear identification methods (e.g. moving-block analysis or time domain techniques). For example, modal interactions can cause the identified damping coefficients to be oscillatory and to assume negative values. Hence, geometric nonlinearities need to be accurately modeled in an adequate plate theory.

The most common nonlinear plate theories use von Karman strains to account for geometric nonlinearities but use linear expressions for the curvatures. The von Karman strains do not account for all geometric nonlinearities due to moderate rotations (Pai and Nayfeh, 1991). Moreover, when the rotations are large, the stress and strain components in von Karman type plate theories do not match the real boundary conditions because they are defined with respect to the undeformed rather than the deformed coordinate system.

In general, both PZT and PVDF are mechanically orthotropic due to manufacturing

and poling processes. Moreover, Lazarus and Crawley (1989) point out that the effects of creep on predicting the actuation strains can be ignored but their hysteretic behavior cannot. To describe the hysteresis, they define two mechanical/electrical coupling coefficients: a one-sided secant coupling coefficient d^+ or d^- and a symmetric or an average secant coupling coefficient d^* . They also point out that the averaged coefficient is more suited for finding the amplitude of the dynamic induced strains. It is also shown by Lazarus and Crawley (1989) and the piezoelectric strain “constants” are not constant but depend on the induced strains. Moreover, the action of a piezoelectric element on a plate element is similar to the loading of a distributed line force, which makes the cross-section warp as the transverse shear forces do.

In this paper, the basic idea underlying the development of our former nonlinear plate theory (Pai and Nayfeh, 1991) is extended to derive a set of mathematically consistent, nonlinear equations governing the motion of laminated piezoelectric plates. The surface analysis is done by using a vector approach, and the resulting expressions for the nonlinear curvatures and mid-plane strains are combined with a layer-wise higher-order shear-deformation theory and the extended Hamilton principle to derive variationally consistent, shear-deformable, nonlinear equations of motion. The theory fully accounts for geometric nonlinearities by using local stress and strain measures and an exact coordinate transformation, which result in nonlinear strain–displacement relations that contain the von Karman strains as a special case. Moreover, the model accounts for the continuity of interlaminar shear stresses, the elastic shear coupling effects, extensionality, orthotropic properties of piezoelectric materials, the dependence of the piezoelectric strain “constants” on the induced strains, integrated actuators and sensors at various orientations, and actuator-induced, local actuating forces and moments. Moreover, actuators and sensors made of PZT and PVDF are considered, the piezoelectric actuator-induced warping is addressed, and comparisons with other simplified models and nonlinear theories are provided.

2. COORDINATE TRANSFORMATION, IN-PLANE STRAINS AND CURVATURES

We consider a rectangular laminated piezoelectric plate over the domain $0 \leq x \leq a$, $0 \leq y \leq b$, $z_1 \leq z \leq z_{N+1}$. In Fig. 1 we show the construction of a typical laminated piezoelectric plate, where the i th lamina is located between the $z = z_i$ and $z = z_{i+1}$ planes, there are N plies, and the thickness $h = z_{N+1} - z_1$. Every composite and piezoelectric lamina is considered orthotropic, and the shapes of the actuators and sensors can be arbitrarily designed, as shown in Fig. 1. We use two coordinate systems, as shown in Fig. 2(a). The x - y - z system coincides with the undeformed configuration of the plate and is an inertial

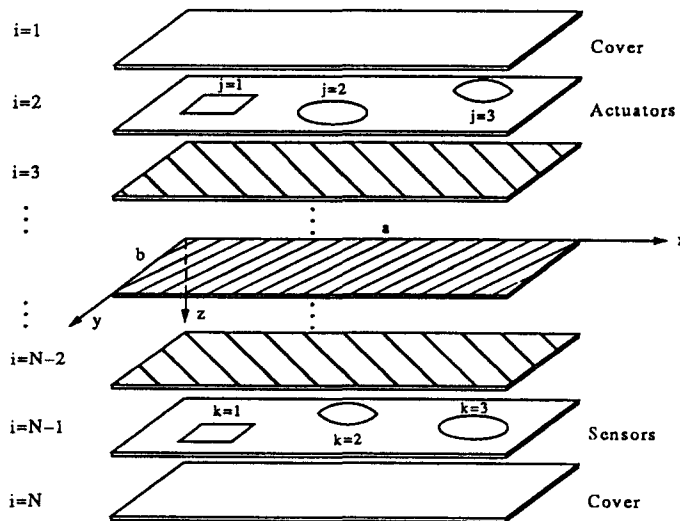

Fig. 1. A typical arrangement of laminated piezoelectric plates.

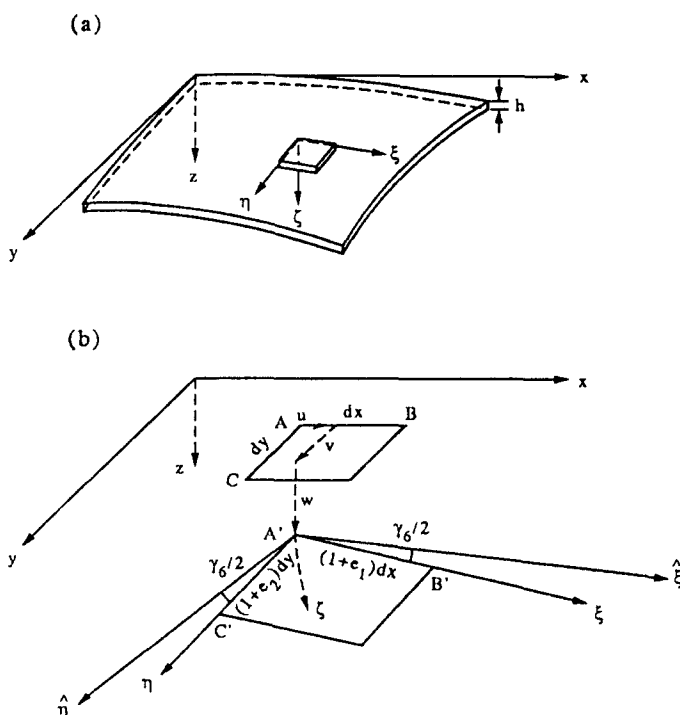

Fig. 2. (a) Coordinate systems: x - y - z = inertial coordinate system; ξ - η - ζ = local coordinate system, which is an orthogonal curvilinear coordinate frame, and (b) the undeformed and deformed geometry of a reference-plane element.

coordinate frame, and the ξ - η - ζ coordinate system is a local, orthogonal curvilinear coordinate system with the ξ and η axes being on the deformed reference-plane. In Fig. 2(b), we show a reference-plane element before and after deformation. Here, \mathbf{i}_x , \mathbf{i}_y and \mathbf{i}_z are unit vectors along the x , y and z axes, respectively; \mathbf{i}_1 , \mathbf{i}_2 and \mathbf{i}_3 are unit vectors along the ξ , η and ζ axes, respectively; and $\hat{\mathbf{i}}_1$ and $\hat{\mathbf{i}}_2$ are unit vectors along the $\hat{\xi}$ and $\hat{\eta}$ axes, respectively. In Fig. 2(b), the coordinates of the corners of the reference-plane element are :

$$\begin{aligned} A &: (x, y, 0), \\ B &: (x + dx, y, 0), \\ C &: (x, y + dy, 0), \\ A' &: (x + u, y + v, w), \\ B' &: (x + dx + u + u_x dx, y + v + v_x dx, w + w_x dx), \\ C' &: (x + u + u_y dy, y + dy + v + v_y dy, w + w_y dy), \end{aligned}$$

where u , v and w are the components of the displacement of corner A . Throughout this paper, the subscripts x , y and z denote partial differentiation with respect to x , y and z , respectively, except that \mathbf{i}_x , \mathbf{i}_y and \mathbf{i}_z denote the base vectors of the x - y - z coordinate system. The other subscripts do not represent differentiation.

It follows from Fig. 2(b) that the axial strains along the ξ and η -directions are given, respectively, by :

$$e_1 = \frac{\overline{A'B'} - dx}{dx} = \sqrt{(1 + u_x)^2 + v_x^2 + w_x^2} - 1, \tag{1}$$

$$e_2 = \frac{\overline{A'C'} - dy}{dy} = \sqrt{u_y^2 + (1 + v_y)^2 + w_y^2} - 1. \tag{2}$$

The unit vectors along the $\hat{\xi}$ and $\hat{\eta}$ directions are given by :

$$\mathbf{i}_1 = \frac{\mathbf{A}'\mathbf{B}'}{(1+e_1)} dx = T_{11}\mathbf{i}_x + T_{12}\mathbf{i}_y + T_{13}\mathbf{i}_z, \tag{3}$$

$$\mathbf{i}_2 = \frac{\mathbf{A}'\mathbf{C}'}{(1+e_2)} dy = T_{21}\mathbf{i}_x + T_{22}\mathbf{i}_y + T_{23}\mathbf{i}_z, \tag{4}$$

where

$$T_{11} = \frac{1+u_x}{1+e_1}, \quad T_{12} = \frac{v_x}{1+e_1}, \quad T_{13} = \frac{w_x}{1+e_1}, \tag{5}$$

$$T_{21} = \frac{u_y}{1+e_2}, \quad T_{22} = \frac{1+v_y}{1+e_2}, \quad T_{23} = \frac{w_y}{1+e_2}. \tag{6}$$

Using eqns (3) and (4), we obtain an expression for the inplane shear deformation as :

$$\gamma_6 = \sin^{-1}(\mathbf{i}_1 \cdot \mathbf{i}_2) = \sin^{-1}(T_{11}T_{21} + T_{12}T_{22} + T_{13}T_{23}), \tag{7}$$

where a bullet denotes an inner product of vectors. Equations (1), (2) and (7) are nonlinear expressions giving the inplane strains e_1, e_2 and γ_6 in terms of the displacements.

Although \mathbf{i}_1 is perpendicular to \mathbf{i}_2 only when the inplane shear strain γ_6 is zero, we neglect the influence of γ_6 on the deformed plate configuration and assume that \mathbf{i}_1 is perpendicular to \mathbf{i}_2 . For a derivation that includes the influence of γ_6 , the reader is referred to Pai and Nayfeh (1991). Then, the unit normal to the deformed reference plane is given by :

$$\mathbf{i}_3 = \frac{\mathbf{i}_1 \times \mathbf{i}_2}{|\mathbf{i}_1 \times \mathbf{i}_2|} = T_{31}\mathbf{i}_x + T_{32}\mathbf{i}_y + T_{33}\mathbf{i}_z, \tag{8}$$

where

$$\begin{aligned} T_{31} &= (T_{12}T_{23} - T_{13}T_{22})/R_0, & T_{32} &= (T_{13}T_{21} - T_{11}T_{23})/R_0, \\ T_{33} &= (T_{11}T_{22} - T_{12}T_{21})/R_0, \\ R_0 &\equiv \sqrt{(T_{12}T_{23} - T_{13}T_{22})^2 + (T_{13}T_{21} - T_{11}T_{23})^2 + (T_{11}T_{22} - T_{12}T_{21})^2}. \end{aligned} \tag{9}$$

Combining eqns (3), (4) and (8), we obtain the following transformation which relates the undeformed coordinate system $x-y-z$ to the deformed coordinate system $\xi-\eta-\zeta$:

$$\{\mathbf{i}_{123}\} = [T]\{\mathbf{i}_{xyz}\}, \quad \{\mathbf{i}_{123}\} \equiv \begin{Bmatrix} \mathbf{i}_1 \\ \mathbf{i}_2 \\ \mathbf{i}_3 \end{Bmatrix}, \quad \{\mathbf{i}_{xyz}\} \equiv \begin{Bmatrix} \mathbf{i}_x \\ \mathbf{i}_y \\ \mathbf{i}_z \end{Bmatrix}, \quad [T] \equiv \begin{bmatrix} T_{11} & T_{12} & T_{13} \\ T_{21} & T_{22} & T_{23} \\ T_{31} & T_{32} & T_{33} \end{bmatrix}. \tag{10}$$

We note that $[T]^{-1} = [T]^T$ due to the orthogonality of the $\xi-\eta-\zeta$ coordinate system.

Using the identities :

$$\frac{\partial \mathbf{i}_j}{\partial x} \cdot \mathbf{i}_j = \frac{\partial \mathbf{i}_j}{\partial y} \cdot \mathbf{i}_j = 0, \quad \frac{\partial \mathbf{i}_j}{\partial x} \cdot \mathbf{i}_k = -\frac{\partial \mathbf{i}_k}{\partial x} \cdot \mathbf{i}_j, \quad \frac{\partial \mathbf{i}_j}{\partial y} \cdot \mathbf{i}_k = -\frac{\partial \mathbf{i}_k}{\partial y} \cdot \mathbf{i}_j \quad \text{for } j, k = 1, 2, 3, \tag{11}$$

we obtain

$$\frac{\partial}{\partial x} \{\mathbf{i}_{123}\} = [\mathbf{K}_1]\{\mathbf{i}_{123}\}, \quad [\mathbf{K}_1] \equiv \begin{bmatrix} 0 & \kappa_5 & -\kappa_1 \\ -\kappa_5 & 0 & -\kappa_{61} \\ \kappa_1 & \kappa_{61} & 0 \end{bmatrix}, \tag{12}$$

$$\frac{\partial}{\partial y} \{\mathbf{i}_{123}\} = [\mathbf{K}_2] \{\mathbf{i}_{123}\}, \quad [\mathbf{K}_2] \equiv \begin{bmatrix} 0 & \kappa_4 & -\kappa_{62} \\ -\kappa_4 & 0 & -\kappa_2 \\ \kappa_{62} & \kappa_2 & 0 \end{bmatrix}, \quad (13)$$

where $[\mathbf{K}_1]$ and $[\mathbf{K}_2]$ are curvature matrices and the curvatures are given by:

$$\kappa_1 \equiv -\frac{\partial \mathbf{i}_1}{\partial x} \cdot \mathbf{i}_3 = -T_{11x}T_{31} - T_{12x}T_{32} - T_{13x}T_{33}, \quad (14)$$

$$\kappa_2 \equiv -\frac{\partial \mathbf{i}_2}{\partial y} \cdot \mathbf{i}_3 = -T_{21y}T_{31} - T_{22y}T_{32} - T_{23y}T_{33}, \quad (15)$$

$$\kappa_{61} \equiv -\frac{\partial \mathbf{i}_2}{\partial x} \cdot \mathbf{i}_3 = -T_{21x}T_{31} - T_{22x}T_{32} - T_{23x}T_{33}, \quad (16)$$

$$\kappa_{62} \equiv -\frac{\partial \mathbf{i}_1}{\partial y} \cdot \mathbf{i}_3 = -T_{11y}T_{31} - T_{12y}T_{32} - T_{13y}T_{33}, \quad (17)$$

$$\kappa_4 \equiv -\frac{\partial \mathbf{i}_2}{\partial y} \cdot \mathbf{i}_1 = -T_{21y}T_{11} - T_{22y}T_{12} - T_{23y}T_{13}, \quad (18)$$

$$\kappa_5 \equiv \frac{\partial \mathbf{i}_1}{\partial x} \cdot \mathbf{i}_2 = T_{11x}T_{21} + T_{12x}T_{22} + T_{13x}T_{23}. \quad (19)$$

Here, κ_1 and κ_2 are the bending curvatures with respect to the η and $-\xi$ axes and κ_{61} and κ_{62} are the twisting curvatures with respect to the $-\xi$ and η axes, respectively. Moreover, eqns (14)–(19) are expressions for the curvatures with respect to the local coordinate system ξ – η – ζ and are normalized, not real, curvatures because the differentiation is taken with respect to the undeformed element lengths dx and dy and not with respect to the deformed lengths $(1+e_1)dx$ and $(1+e_2)dy$.

3. DISPLACEMENT FIELD, SHEAR WARPINGS AND STRAINS

Here we treat each composite or piezoelectric lamina as an orthotropic layer, as shown in Fig. 1. Because some parts of an actuation or sensing lamina are made of adhesives and not piezoelectric materials, the stiffness properties of such lamina and hence the global stiffness matrix of the laminated plate vary over the area. But because the mechanical stiffnesses of piezoelectric materials (especially PVDF) are usually much smaller than the composite laminae and because the piezoelectric laminae are very thin, one can assume that the piezoelectric laminae are uniform and take the stiffnesses to be appropriate averaged values of those of the piezoelectric and adhesive materials, thereby obtaining a constant global plate stiffness matrix. Of course, if a finite-element method is used, this nonuniformity can be fully accounted for.

For a piezoelectric plate, there are four kinds of loads—piezoelectric-actuator-induced local loads, restrained-boundaries-induced loads, external loads and inertial loads. In Fig. 3(a), we show a cross-section of an undeformed plate segment. A typical deformation due to external, inertial and/or restrained-boundary-induced loads is shown in Fig. 3(b). For a plate with free boundaries and no external or inertial loads, a typical deformation due to piezoelectric actuation is shown in Fig. 3(c). A real deformation is a combination of both. Because the warping functions in Figs 3(b) and 3(c) are different, we need to obtain these warping functions separately.

To fully account for the change in configuration, we use local stress and strain measures and a coordinate transformation. The movement of a plate element consists of two parts: a rigid-body motion, which translates the corner A of the reference-plane element from $(x,$

$y, 0$) to $(x+u, y+v, w)$ and rotates its dx - and dy -sides to be parallel to the $\hat{\xi}$ and $\hat{\eta}$ axes, respectively; and a local displacement, which results in the strains. Because the rigid-body motion does not result in any strain energy, to obtain the elastic energy we only need to deal with the local strainable displacements.

3.1. External load-induced displacement field

To include shear deformations in the mathematical model of a general anisotropic laminated plate subjected to external, inertial and/or restrained-boundary-induced loads [see Fig. 3(b)], we assume a displacement field for each layer because the material properties are not uniform through the thickness. Using assumptions similar to those used by Pai and Nayfeh (1991), we assume that the local displacements $u_1^{(i)}$, $u_2^{(i)}$ and $u_3^{(i)}$ (with respect to the ξ - η - ζ coordinate system) of the i th lamina have the form :

$$u_1^{(i)}(x, y, z, t) = u_1^0(x, y, t) + z\theta_2(x, y, t) + \gamma_5 z + \alpha_1^{(i)}(x, y, t)z^2 + \beta_1^{(i)}(x, y, t)z^3, \quad (20a)$$

$$u_2^{(i)}(x, y, z, t) = u_2^0(x, y, t) - z\theta_1(x, y, t) + \gamma_4 z + \alpha_2^{(i)}(x, y, t)z^2 + \beta_2^{(i)}(x, y, t)z^3, \quad (20b)$$

$$u_3^{(i)}(x, y, z, t) = u_3^0(x, y, t), \quad (20c)$$

where t denotes time, the $u_i^0 (i = 1, 2, 3)$ are the displacements (with respect to the local coordinate system) of a point which is located at $(x, y, 0)$ before deformation, γ_4 and γ_5 are the transverse shear rotations at the reference plane with respect to the $-\xi$ and η axes.

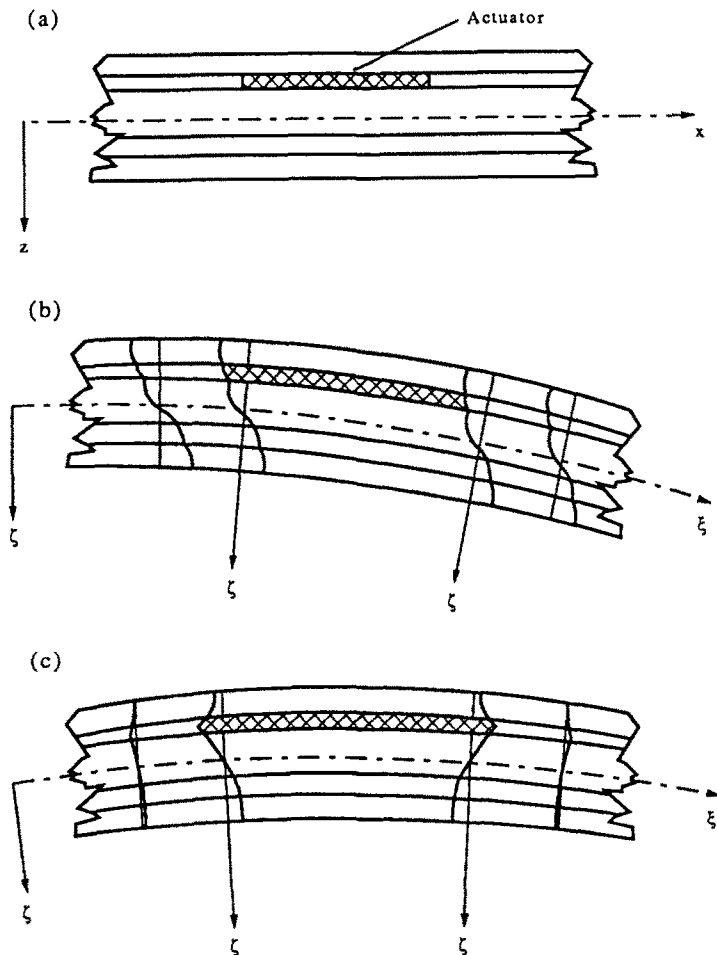

Fig. 3. (a) A cross-section of the undeformed plate, (b) the deformation due to external, inertial, and/or restrained-boundary-induced loads, and (c) actuator-induced deformation.

respectively, and θ_1 and θ_2 are the rotation angles of the normal to the reference plane with respect to the ξ and η axes, respectively. Moreover, the $\alpha_i^{(j)}$ and $\beta_j^{(i)}$ are functions to be determined by imposing continuity conditions on the inplane displacements and interlaminar shear stresses and the free surface conditions. Because ξ - η - ζ is a local coordinate system and the ξ - η plane is tangent to the deformed reference-plane, we have:

$$u_1^0 = u_2^0 = u_3^0 = \theta_1 = \theta_2 = \partial u_3^0 / \partial X = \partial u_3^0 / \partial Y = 0. \quad (21)$$

Using eqns (20) and (21), we obtain the local transverse shear strains as:

$$\epsilon_{23}^{(j)} = \frac{\partial u_2^{(j)}}{\partial z} + \frac{\partial u_3^{(j)}}{\partial y} = \gamma_4 + 2\alpha_2^{(j)}z + 3\beta_2^{(j)}z^2, \quad (22a)$$

$$\epsilon_{13}^{(j)} = \frac{\partial u_1^{(j)}}{\partial z} + \frac{\partial u_3^{(j)}}{\partial x} = \gamma_5 + 2\alpha_1^{(j)}z + 3\beta_1^{(j)}z^2. \quad (22b)$$

Using tensor transformations (Whitney, 1987), one can relate the transformed stiffness matrix $[\bar{Q}^{(j)}]$ for the i th lamina to its principal stiffness matrix $[Q^{(j)}]$ and its ply angle, thereby obtaining the stress-strain relations for the i th lamina as:

$$\begin{Bmatrix} \sigma_{11}^{(j)} \\ \sigma_{22}^{(j)} \\ \sigma_{33}^{(j)} \\ \sigma_{23}^{(j)} \\ \sigma_{13}^{(j)} \\ \sigma_{12}^{(j)} \end{Bmatrix} = \begin{bmatrix} \bar{Q}_{11}^{(j)} & \bar{Q}_{12}^{(j)} & \bar{Q}_{13}^{(j)} & 0 & 0 & \bar{Q}_{16}^{(j)} \\ \bar{Q}_{12}^{(j)} & \bar{Q}_{22}^{(j)} & \bar{Q}_{23}^{(j)} & 0 & 0 & \bar{Q}_{26}^{(j)} \\ \bar{Q}_{13}^{(j)} & \bar{Q}_{23}^{(j)} & \bar{Q}_{33}^{(j)} & 0 & 0 & \bar{Q}_{36}^{(j)} \\ 0 & 0 & 0 & \bar{Q}_{44}^{(j)} & \bar{Q}_{45}^{(j)} & 0 \\ 0 & 0 & 0 & \bar{Q}_{45}^{(j)} & \bar{Q}_{55}^{(j)} & 0 \\ \bar{Q}_{16}^{(j)} & \bar{Q}_{26}^{(j)} & \bar{Q}_{36}^{(j)} & 0 & 0 & \bar{Q}_{66}^{(j)} \end{bmatrix} \begin{Bmatrix} \epsilon_{11}^{(j)} \\ \epsilon_{22}^{(j)} \\ \epsilon_{33}^{(j)} \\ \epsilon_{23}^{(j)} \\ \epsilon_{13}^{(j)} \\ \epsilon_{12}^{(j)} \end{Bmatrix}. \quad (23)$$

We assume that there is no delamination, and hence the inplane displacements u_1 and u_2 and interlaminar shear stresses σ_{13} and σ_{23} are continuous across the interface of two contiguous laminae. Moreover, we assume that there are no applied shear loads on the bounding surfaces and hence $\sigma_{13} = \sigma_{23} = 0$ at the $z = z_1$ and $z = z_{N+1}$ planes. Hence, we have:

$$\begin{aligned} \epsilon_{13}^{(1)}(x, y, z_1, t) &= 0, \\ \epsilon_{23}^{(1)}(x, y, z_1, t) &= 0, \\ u_1^{(j)}(x, y, z_{i+1}, t) - u_1^{(j+1)}(x, y, z_{i+1}, t) &= 0 \quad \text{for } i = 1, \dots, N-1, \\ u_2^{(j)}(x, y, z_{i+1}, t) - u_2^{(j+1)}(x, y, z_{i+1}, t) &= 0 \quad \text{for } i = 1, \dots, N-1, \\ \sigma_{23}^{(j)}(x, y, z_{i+1}, t) - \sigma_{23}^{(j+1)}(x, y, z_{i+1}, t) &= 0 \quad \text{for } i = 1, \dots, N-1, \\ \sigma_{13}^{(j)}(x, y, z_{i+1}, t) - \sigma_{13}^{(j+1)}(x, y, z_{i+1}, t) &= 0 \quad \text{for } i = 1, \dots, N-1, \\ \epsilon_{13}^{(N)}(x, y, z_{N+1}, t) &= 0, \\ \epsilon_{23}^{(N)}(x, y, z_{N+1}, t) &= 0. \end{aligned} \quad (24)$$

These $4N$ algebraic equations can be used to determine the $4N$ unknowns (i.e. $\alpha_1^{(j)}$, $\alpha_2^{(j)}$, $\beta_1^{(j)}$, $\beta_2^{(j)}$ for $i = 1, \dots, N$), by using eqns (22), (20a), (20b) and (23), in terms of γ_4 and γ_5 as:

$$\begin{aligned} \alpha_1^{(j)} &= a_{14}^{(j)}\gamma_4 + a_{15}^{(j)}\gamma_5, \\ \alpha_2^{(j)} &= a_{24}^{(j)}\gamma_4 + a_{25}^{(j)}\gamma_5, \\ \beta_1^{(j)} &= b_{14}^{(j)}\gamma_4 + b_{15}^{(j)}\gamma_5, \\ \beta_2^{(j)} &= b_{24}^{(j)}\gamma_4 + b_{25}^{(j)}\gamma_5, \end{aligned} \quad (25)$$

for $i = 1, \dots, N$, where the $a_k^{(j)}$ and $b_k^{(j)}$ are functions of the z_j , $\bar{Q}_{44}^{(j)}$, $\bar{Q}_{45}^{(j)}$ and $\bar{Q}_{55}^{(j)}$.

3.2. A general displacement field and strains

It follows from eqns (20) and (25) that a general displacement field describing the deformation due to any load can be represented by

$$u_1^{(i)}(x, y, z, t) = u_1^0(x, y, t) + z\theta_2(x, y, t) + \gamma_5 g_{15}^{(i)} + \gamma_4 g_{14}^{(i)}, \quad (26a)$$

$$u_2^{(i)}(x, y, z, t) = u_2^0(x, y, t) - z\theta_1(x, y, t) + \gamma_4 g_{24}^{(i)} + \gamma_5 g_{25}^{(i)}, \quad (26b)$$

$$u_3^{(i)}(x, y, z, t) = u_3^0(x, y, t), \quad (26c)$$

where the $g_{14}^{(i)}$, $g_{15}^{(i)}$, $g_{24}^{(i)}$ and $g_{25}^{(i)}$ are polynomial functions of z . For example, eqns (20) and (25) can be rewritten in the form of eqns (26) with :

$$\begin{aligned} g_{14}^{(i)} &\equiv a_{14}^{(i)}z^2 + b_{14}^{(i)}z^3, \\ g_{15}^{(i)} &\equiv z + a_{15}^{(i)}z^2 + b_{15}^{(i)}z^3, \\ g_{24}^{(i)} &\equiv z + a_{24}^{(i)}z^2 + b_{24}^{(i)}z^3, \\ g_{25}^{(i)} &\equiv a_{25}^{(i)}z^2 + b_{25}^{(i)}z^3. \end{aligned} \quad (27)$$

Using equations (26) and (21), we obtain the local strains as :

$$\begin{Bmatrix} \varepsilon_{11}^{(i)} \\ \varepsilon_{22}^{(i)} \\ \varepsilon_{12}^{(i)} \end{Bmatrix} = \begin{Bmatrix} \partial u_1^{(i)} / \partial x \\ \partial u_2^{(i)} / \partial y \\ \partial u_1^{(i)} / \partial y + \partial u_2^{(i)} / \partial x \end{Bmatrix} = [S_1^{(i)}] \{\psi\}, \quad (28a)$$

$$\begin{Bmatrix} \varepsilon_{23}^{(i)} \\ \varepsilon_{13}^{(i)} \end{Bmatrix} = \begin{Bmatrix} \frac{\partial u_2^{(i)}}{\partial z} + \frac{\partial u_3^{(i)}}{\partial y} \\ \frac{\partial u_1^{(i)}}{\partial z} + \frac{\partial u_3^{(i)}}{\partial x} \end{Bmatrix} = [S_2^{(i)}] \begin{Bmatrix} \gamma_4 \\ \gamma_5 \end{Bmatrix}, \quad (28b)$$

where

$$[S_1^{(i)}] \equiv \begin{bmatrix} 1 & 0 & 0 & z & 0 & 0 & g_{14}^{(i)} & 0 & g_{15}^{(i)} & 0 \\ 0 & 1 & 0 & 0 & z & 0 & 0 & g_{24}^{(i)} & 0 & g_{25}^{(i)} \\ 0 & 0 & 1 & 0 & 0 & z & g_{24}^{(i)} & g_{14}^{(i)} & g_{25}^{(i)} & g_{15}^{(i)} \end{bmatrix}, \quad (29a)$$

$$[S_2^{(i)}] \equiv \begin{bmatrix} g_{24z}^{(i)} & g_{25z}^{(i)} \\ g_{14z}^{(i)} & g_{15z}^{(i)} \end{bmatrix}, \quad (29b)$$

$$\{\psi\} \equiv \{e_1, e_2, \gamma_6, \kappa_1, \kappa_2, \kappa_6, \gamma_{4x}, \gamma_{4y}, \gamma_{5x}, \gamma_{5y}\}^T. \quad (29c)$$

Moreover,

$$e_1 \equiv \frac{\partial u_1^0}{\partial x}, \quad e_2 \equiv \frac{\partial u_2^0}{\partial y}, \quad \gamma_6 \equiv \frac{\partial u_1^0}{\partial y} + \frac{\partial u_2^0}{\partial x}, \quad (29d)$$

$$\kappa_1 \equiv \frac{\partial \theta_2}{\partial x}, \quad \kappa_2 \equiv -\frac{\partial \theta_1}{\partial y}, \quad \kappa_{61} \equiv -\frac{\partial \theta_1}{\partial x}, \quad \kappa_{62} \equiv \frac{\partial \theta_2}{\partial y}, \quad \kappa_6 \equiv \kappa_{61} + \kappa_{62}, \quad (29e)$$

because $\xi-\eta-\zeta$ is a local coordinate system and the $\xi-\eta$ plane is tangent to the deformed reference-plane.

Because the orthotropy of piezoelectric laminae is due to manufacturing and poling processes, we assume that the principal mechanical or material directions are the same as the principal piezoelectric directions. Also, we use the assumption that $\sigma_{33}^{(i)} = 0$, include induced-strain actuators, and obtain the stress-strain relations:

$$\begin{Bmatrix} \sigma_{11}^{(i)} \\ \sigma_{22}^{(i)} \\ \sigma_{12}^{(i)} \end{Bmatrix} = [\tilde{Q}^{(i)}] \begin{Bmatrix} \varepsilon_{11}^{(i)} - \bar{\Lambda}_1 R \\ \varepsilon_{22}^{(i)} - \bar{\Lambda}_2 R \\ \varepsilon_{12}^{(i)} - \bar{\Lambda}_{12} R \end{Bmatrix}, \quad \begin{Bmatrix} \sigma_{23}^{(i)} \\ \sigma_{13}^{(i)} \end{Bmatrix} = [\hat{Q}^{(i)}] \begin{Bmatrix} \varepsilon_{23}^{(i)} \\ \varepsilon_{13}^{(i)} \end{Bmatrix}, \quad (30)$$

where

$$[\tilde{Q}^{(i)}] \equiv \begin{bmatrix} \tilde{Q}_{11}^{(i)} & \tilde{Q}_{12}^{(i)} & \tilde{Q}_{16}^{(i)} \\ \tilde{Q}_{12}^{(i)} & \tilde{Q}_{22}^{(i)} & \tilde{Q}_{26}^{(i)} \\ \tilde{Q}_{16}^{(i)} & \tilde{Q}_{26}^{(i)} & \tilde{Q}_{66}^{(i)} \end{bmatrix}, \quad [\hat{Q}^{(i)}] \equiv \begin{bmatrix} \tilde{Q}_{44}^{(i)} & \tilde{Q}_{45}^{(i)} \\ \tilde{Q}_{45}^{(i)} & \tilde{Q}_{55}^{(i)} \end{bmatrix}, \quad (31)$$

$$\begin{aligned} \Lambda_1 &= \frac{d_{31} V_3}{z_{l+1} - z_l}, & \Lambda_2 &= \frac{d_{32} V_3}{z_{l+1} - z_l}, \\ \bar{\Lambda}_1 &= \Lambda_1 \cos^2 \alpha + \Lambda_2 \sin^2 \alpha, \\ \bar{\Lambda}_2 &= \Lambda_1 \sin^2 \alpha + \Lambda_2 \cos^2 \alpha, \\ \bar{\Lambda}_{12} &= 2 \cos \alpha \sin \alpha (\Lambda_1 - \Lambda_2). \end{aligned} \quad (32)$$

Here, V_3 is the applied voltage across the actuator which is located between the $z = z_l$ and $z = z_{l+1}$ planes; d_{31} and d_{32} are the piezoelectric strain constants with respect to the principal piezoelectric directions 1 and 2 (see Fig. 4), which may be functions of the induced strains ε_{11} and ε_{22} (Lazarus and Crawley, 1989); Λ_1 and Λ_2 are the free actuating strains along the 1 and 2 directions, respectively; $\bar{\Lambda}_1$ and $\bar{\Lambda}_2$ are the free actuating strains along the deformed structural axes ξ and η ; $\bar{\Lambda}_{12}$ is the inplane shear actuating strain (Lazarus and Crawley, 1989; Jones, 1975); α is the angle between the axes 1 and ξ ; and R is a function that describes the location of the actuator, which is given by:

$$R = [H(z - z_l) - H(z - z_{l+1})]L(x, y), \quad (33a)$$

where $H(z)$ is the Heaviside step function defined as

$$\begin{aligned} H(z) &= 1, & z > 0, \\ &= 0, & z < 0. \end{aligned} \quad (33b)$$

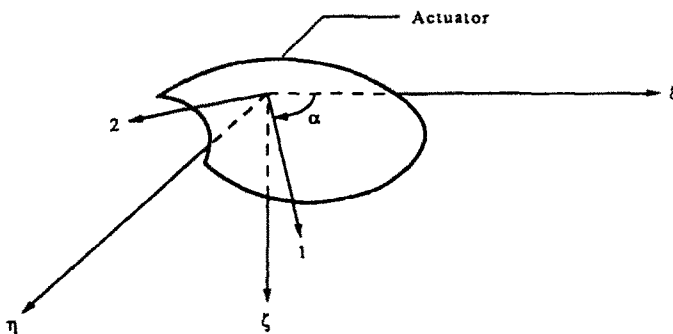

Fig. 4. The principal piezoelectric directions (1 and 2) of a piezoelectric actuator.

$L(x, y)$ describes the location of the actuator on the reference plane and is defined as :

$$L(x, y) = \pm 1 \quad \text{if the point } (x, y) \text{ is covered by the actuator,}$$

$$= 0 \quad \text{if the point } (x, y) \text{ is not covered by the actuator,} \quad (33c)$$

where the \pm signs are used to account for the possibility that the piezoelectric material can have different poling directions on the same lamina (Lee, 1990). For example, if the actuator is a rectangular one, then

$$L(x, y) = \pm [H(x - x_{j1}) - H(x - x_{j2})][H(y - y_{j1}) - H(y - y_{j2})], \quad (33d)$$

where $x = x_{j1}$, $x = x_{j2}$, $y = y_{j1}$ and $y = y_{j2}$ represent the border lines of the j th actuator on the l th lamina.

It follows from eqn (30) that the stresses are proportional to the mechanical strains, which are the difference between the total strains ($e_{kl}^{(j)}$) and the free actuation strains ($\bar{\Lambda}_1, \bar{\Lambda}_2, \bar{\Lambda}_{12}$). Also, eqns (30) and (32) show that an induced strain actuator can only introduce inplane extension or compression and/or inplane shear deformations.

3.3. Actuator-induced displacement field

To solve for the actuator induced warpings with free boundaries and no external or inertial loads, we assume that the displacement field for the i th composite lamina has the same form given eqns (26) and (27), but the values of the $a_{kl}^{(i)}$ and $b_{kl}^{(i)}$ are different from those in eqns (25). For the actuator located at the l th lamina, we assume that its displacement field is the same as that given by eqns (26) but :

$$g_{14}^{(i)} \equiv a_{14}^{(i)}z^2 + b_{14}^{(i)}z^3 + c_{14}^{(i)}z^4,$$

$$g_{15}^{(i)} \equiv z + a_{15}^{(i)}z^2 + b_{15}^{(i)}z^3 + c_{15}^{(i)}z^4 + \bar{c}_{15}^{(i)}z^5,$$

$$g_{24}^{(i)} \equiv z + a_{24}^{(i)}z^2 + b_{24}^{(i)}z^3 + c_{24}^{(i)}z^4 + \bar{c}_{24}^{(i)}z^5,$$

$$g_{25}^{(i)} \equiv a_{25}^{(i)}z^2 + b_{25}^{(i)}z^3 + c_{25}^{(i)}z^4. \quad (34)$$

Because the peak of the warping function should be at the actuation layer and the signs of the shear angle change within the actuation layer, we assume that :

$$g_{15z}(z_i) + g_{15z}(z_{i+1}) = g_{24z}(z_i) + g_{24z}(z_{i+1}) = 0. \quad (35a)$$

Because a thin piezoelectric actuator can only provide inplane strains ϵ_{11} , ϵ_{22} and ϵ_{12} but not transverse shear actuating forces, we have :

$$\sum_{i=1}^N \int_{z_i}^{z_{i+1}} \sigma_{23}^{(i)} dz = \sum_{i=1}^N \int_{z_i}^{z_{i+1}} \sigma_{13}^{(i)} dz = 0. \quad (35b)$$

Substituting eqns (27), (34), (26), (28b) and (30) into eqns (24) and (35) and then setting each of the coefficients of γ_4 and γ_5 equal to zero yields :

$$2a_{14}^{(1)}z_1 + 3b_{14}^{(1)}z_1^2 + \delta_{1l}4c_{14}^{(1)}z_1^3 = 0,$$

$$2a_{15}^{(1)}z_1 + 3b_{15}^{(1)}z_1^2 + \delta_{1l}4c_{15}^{(1)}z_1^3 + \delta_{1l}5\bar{c}_{15}^{(1)}z_1^4 = -1,$$

$$2a_{24}^{(1)}z_1 + 3b_{24}^{(1)}z_1^2 + \delta_{1l}4c_{24}^{(1)}z_1^3 + \delta_{1l}5\bar{c}_{24}^{(1)}z_1^4 = -1,$$

$$2a_{25}^{(1)}z_1 + 3b_{25}^{(1)}z_1^2 + \delta_{1l}4c_{25}^{(1)}z_1^3 = 0. \quad (36a)$$

$$\begin{aligned}
& a_{14}^{(i)}z_j^2 + b_{14}^{(i)}z_j^3 + \delta_{ii}c_{14}^{(i)}z_j^4 - a_{14}^{(i)}z_j^2 - b_{14}^{(i)}z_j^3 - \delta_{ii}c_{14}^{(i)}z_j^4 = 0, \\
& a_{15}^{(i)}z_j^2 + b_{15}^{(i)}z_j^3 + \delta_{ii}c_{15}^{(i)}z_j^4 + \delta_{ii}\bar{c}_{15}^{(i)}z_j^5 - a_{15}^{(i)}z_j^2 - b_{15}^{(i)}z_j^3 - \delta_{ii}c_{15}^{(i)}z_j^4 - \delta_{ii}\bar{c}_{15}^{(i)}z_j^5 = 0, \\
& a_{24}^{(i)}z_j^2 + b_{24}^{(i)}z_j^3 + \delta_{ii}c_{24}^{(i)}z_j^4 + \delta_{ii}\bar{c}_{24}^{(i)}z_j^5 - a_{24}^{(i)}z_j^2 - b_{24}^{(i)}z_j^3 - \delta_{ii}c_{24}^{(i)}z_j^4 - \delta_{ii}\bar{c}_{24}^{(i)}z_j^5 = 0, \\
& a_{25}^{(i)}z_j^2 + b_{25}^{(i)}z_j^3 + \delta_{ii}c_{25}^{(i)}z_j^4 - a_{25}^{(i)}z_j^2 - b_{25}^{(i)}z_j^3 - \delta_{ii}c_{25}^{(i)}z_j^4 = 0, \\
& \bar{Q}_{44}^{(i)}(2a_{24}^{(i)}z_j + 3b_{24}^{(i)}z_j^2 + \delta_{ii}4c_{24}^{(i)}z_j^3 + \delta_{ii}5\bar{c}_{24}^{(i)}z_j^4) + \bar{Q}_{45}^{(i)}(2a_{14}^{(i)}z_j + 3b_{14}^{(i)}z_j^2 + \delta_{ii}4c_{14}^{(i)}z_j^3) \\
& \quad - \bar{Q}_{44}^{(i)}(2a_{24}^{(i)}z_j + 3b_{24}^{(i)}z_j^2 + \delta_{ii}4c_{24}^{(i)}z_j^3 + \delta_{ii}5\bar{c}_{24}^{(i)}z_j^4) \\
& \quad - \bar{Q}_{45}^{(i)}(2a_{14}^{(i)}z_j + 3b_{14}^{(i)}z_j^2 + \delta_{ii}4c_{14}^{(i)}z_j^3) = \bar{Q}_{44}^{(i)} - \bar{Q}_{44}^{(i)}, \\
& \bar{Q}_{44}^{(i)}(2a_{25}^{(i)}z_j + 3b_{25}^{(i)}z_j^2 + \delta_{ii}4c_{25}^{(i)}z_j^3) + \bar{Q}_{45}^{(i)}(2a_{15}^{(i)}z_j + 3b_{15}^{(i)}z_j^2 + \delta_{ii}4c_{15}^{(i)}z_j^3 + \delta_{ii}5\bar{c}_{15}^{(i)}z_j^4) \\
& \quad - \bar{Q}_{44}^{(i)}(2a_{25}^{(i)}z_j + 3b_{25}^{(i)}z_j^2 + \delta_{ii}4c_{25}^{(i)}z_j^3) \\
& \quad - \bar{Q}_{45}^{(i)}(2a_{15}^{(i)}z_j + 3b_{15}^{(i)}z_j^2 + \delta_{ii}4c_{15}^{(i)}z_j^3 + \delta_{ii}5\bar{c}_{15}^{(i)}z_j^4) = \bar{Q}_{45}^{(i)} - \bar{Q}_{45}^{(i)}, \\
& \bar{Q}_{45}^{(i)}(2a_{24}^{(i)}z_j + 3b_{24}^{(i)}z_j^2 + \delta_{ii}4c_{24}^{(i)}z_j^3 + \delta_{ii}5\bar{c}_{24}^{(i)}z_j^4) + \bar{Q}_{55}^{(i)}(2a_{14}^{(i)}z_j + 3b_{14}^{(i)}z_j^2 + \delta_{ii}4c_{14}^{(i)}z_j^3) \\
& \quad - \bar{Q}_{45}^{(i)}(2a_{24}^{(i)}z_j + 3b_{24}^{(i)}z_j^2 + \delta_{ii}4c_{24}^{(i)}z_j^3 + \delta_{ii}5\bar{c}_{24}^{(i)}z_j^4) \\
& \quad - \bar{Q}_{55}^{(i)}(2a_{14}^{(i)}z_j + 3b_{14}^{(i)}z_j^2 + \delta_{ii}4c_{14}^{(i)}z_j^3) = \bar{Q}_{45}^{(i)} - \bar{Q}_{45}^{(i)}, \\
& \bar{Q}_{45}^{(i)}(2a_{25}^{(i)}z_j + 3b_{25}^{(i)}z_j^2 + \delta_{ii}4c_{25}^{(i)}z_j^3) + \bar{Q}_{55}^{(i)}(2a_{15}^{(i)}z_j + 3b_{15}^{(i)}z_j^2 + \delta_{ii}4c_{15}^{(i)}z_j^3 + \delta_{ii}5\bar{c}_{15}^{(i)}z_j^4) \\
& \quad - \bar{Q}_{45}^{(i)}(2a_{25}^{(i)}z_j + 3b_{25}^{(i)}z_j^2 + \delta_{ii}4c_{25}^{(i)}z_j^3) \\
& \quad - \bar{Q}_{55}^{(i)}(2a_{15}^{(i)}z_j + 3b_{15}^{(i)}z_j^2 + \delta_{ii}4c_{15}^{(i)}z_j^3 + \delta_{ii}5\bar{c}_{15}^{(i)}z_j^4) = \bar{Q}_{55}^{(i)} - \bar{Q}_{55}^{(i)}, \tag{36b}
\end{aligned}$$

for $i = 1, \dots, N-1$, where $j \equiv i+1$.

$$\begin{aligned}
& 2a_{14}^{(N)}z_{N+1} + 3b_{14}^{(N)}z_{N+1}^2 + \delta_{NN}4c_{14}^{(N)}z_{N+1}^3 = 0, \\
& 2a_{15}^{(N)}z_{N+1} + 3b_{15}^{(N)}z_{N+1}^2 + \delta_{NN}4c_{15}^{(N)}z_{N+1}^3 + \delta_{NN}5\bar{c}_{15}^{(N)}z_{N+1}^4 = -1, \\
& 2a_{24}^{(N)}z_{N+1} + 3b_{24}^{(N)}z_{N+1}^2 + \delta_{NN}4c_{24}^{(N)}z_{N+1}^3 + \delta_{NN}5\bar{c}_{24}^{(N)}z_{N+1}^4 = -1, \\
& 2a_{25}^{(N)}z_{N+1} + 3b_{25}^{(N)}z_{N+1}^2 + \delta_{NN}4c_{25}^{(N)}z_{N+1}^3 = 0. \tag{36c}
\end{aligned}$$

$$\begin{aligned}
& 2a_{15}^{(i)}(z_i + z_{i+1}) + 3b_{15}^{(i)}(z_i^2 + z_{i+1}^2) + 4c_{15}^{(i)}(z_i^3 + z_{i+1}^3) + 5\bar{c}_{15}^{(i)}(z_i^4 + z_{i+1}^4) = -2, \\
& 2a_{24}^{(i)}(z_i + z_{i+1}) + 3b_{24}^{(i)}(z_i^2 + z_{i+1}^2) + 4c_{24}^{(i)}(z_i^3 + z_{i+1}^3) + 5\bar{c}_{24}^{(i)}(z_i^4 + z_{i+1}^4) = -2. \tag{36d}
\end{aligned}$$

$$\begin{aligned}
& \sum_{i=1}^N \int_{z_i}^{z_{i+1}} [\bar{Q}_{44}^{(i)}(1 + 2a_{24}^{(i)}z + 3b_{24}^{(i)}z^2 + \delta_{ii}4c_{24}^{(i)}z^3 + \delta_{ii}5\bar{c}_{24}^{(i)}z^4) \\
& \quad + \bar{Q}_{45}^{(i)}(2a_{14}^{(i)}z + 3b_{14}^{(i)}z^2 + \delta_{ii}4c_{14}^{(i)}z^3)] dz = 0, \\
& \sum_{i=1}^N \int_{z_i}^{z_{i+1}} [\bar{Q}_{44}^{(i)}(2a_{25}^{(i)}z + 3b_{25}^{(i)}z^2 + \delta_{ii}4c_{25}^{(i)}z^3) + \bar{Q}_{45}^{(i)}(1 + 2a_{15}^{(i)}z + 3b_{15}^{(i)}z^2 \\
& \quad + \delta_{ii}4c_{15}^{(i)}z^3 + \delta_{ii}5\bar{c}_{15}^{(i)}z^4)] dz = 0, \\
& \sum_{i=1}^N \int_{z_i}^{z_{i+1}} [\bar{Q}_{45}^{(i)}(1 + 2a_{24}^{(i)}z + 3b_{24}^{(i)}z^2 + \delta_{ii}4c_{24}^{(i)}z^3 + \delta_{ii}5\bar{c}_{24}^{(i)}z^4) \\
& \quad + \bar{Q}_{55}^{(i)}(2a_{14}^{(i)}z + 3b_{14}^{(i)}z^2 + \delta_{ii}4c_{14}^{(i)}z^3)] dz = 0, \\
& \sum_{i=1}^N \int_{z_i}^{z_{i+1}} [\bar{Q}_{45}^{(i)}(2a_{25}^{(i)}z + 3b_{25}^{(i)}z^2 + \delta_{ii}4c_{25}^{(i)}z^3) + \bar{Q}_{55}^{(i)}(1 + 2a_{15}^{(i)}z + 3b_{15}^{(i)}z^2 \\
& \quad + \delta_{ii}4c_{15}^{(i)}z^3 + \delta_{ii}5\bar{c}_{15}^{(i)}z^4)] dz = 0, \tag{36e}
\end{aligned}$$

where δ_{ii} is the Kronecker delta function. These $8N+6$ algebraic equations can be solved for the $8N+6$ unknowns— $a_{14}^{(i)}$, $a_{15}^{(i)}$, $a_{24}^{(i)}$, $a_{25}^{(i)}$, $b_{14}^{(i)}$, $b_{15}^{(i)}$, $b_{24}^{(i)}$, $b_{25}^{(i)}$, for $i = 1, \dots, N$, and $\bar{c}_{15}^{(i)}$, $\bar{c}_{24}^{(i)}$, $c_{14}^{(i)}$, $c_{15}^{(i)}$, $c_{24}^{(i)}$, $c_{25}^{(i)}$. We note that the reference plane cannot be chosen as the contacting

surface of any two laminae because it will make the shear angles continuous at $z = 0$. Also, we note that eqns (24) are a special case of eqns (36). If there are several actuators covering the same area of the reference plane, a superposition method can be applied to obtain the warping functions if the input voltages to these actuators are proportional to one another.

For areas not covered by actuators, we propose to use the shear warpings shown in Fig. 3(b). For the areas covered by actuators, we propose to use the shear warpings shown in Fig. 3(c) if there are no externally applied loads. An appropriate combination of both warping functions will be used in the presence of externally applied loads.

4. FORMULATION

Because there are difficulties involved in solving dynamic problems for a general anisotropic plate, approximate or numerical methods are usually adopted and hence energy formulations are much more practical. Here we use the extended Hamilton principle to derive the equations of motion :

$$0 = \int_0^t (\delta T - \delta V + \delta W_{nc}) dt, \tag{37}$$

where δW_{nc} denotes the variation of the nonconservative energy W_{nc} , which is problem dependent and will not be considered in the derivation, and the variations of the kinetic and elastic energies T and V are given by :

$$\delta T = - \sum_{i=1}^N \int_{z_i}^{z_{i+1}} \int_A \rho^{(i)} \dot{\mathbf{D}} \cdot \delta \mathbf{D} dA dz, \tag{38a}$$

$$\delta V = \sum_{i=1}^N \int_{z_i}^{z_{i+1}} \int_A \left(\mathbf{t}_1 \cdot \delta \frac{\partial \mathbf{U}}{\partial x} + \mathbf{t}_2 \cdot \delta \frac{\partial \mathbf{U}}{\partial y} + \mathbf{t}_3 \cdot \delta \frac{\partial \mathbf{U}}{\partial z} \right) dA dz. \tag{38b}$$

Here, $\rho^{(i)}$ is the mass density of the i th layer, A denotes the undeformed area of the reference plane, and $\dot{\mathbf{D}} \equiv d^2\mathbf{D}/dt^2$. The tractions \mathbf{t}_i are given by :

$$\begin{aligned} \mathbf{t}_1 &\equiv \sigma_{11}^{(i)} \mathbf{i}_1 + \sigma_{12}^{(i)} \mathbf{i}_2 + \sigma_{13}^{(i)} \mathbf{i}_3, \\ \mathbf{t}_2 &\equiv \sigma_{21}^{(i)} \mathbf{i}_1 + \sigma_{22}^{(i)} \mathbf{i}_2 + \sigma_{23}^{(i)} \mathbf{i}_3, \\ \mathbf{t}_3 &\equiv \sigma_{31}^{(i)} \mathbf{i}_1 + \sigma_{32}^{(i)} \mathbf{i}_2, \end{aligned} \tag{39a}$$

the absolute displacement vector \mathbf{D} of a particle in the observed plate element is given by :

$$\mathbf{D} = u\mathbf{i}_x + v\mathbf{i}_y + w\mathbf{i}_z + z\mathbf{i}_3 - z\mathbf{i}_2 + u_1^{(i)}\mathbf{i}_1 + u_2^{(i)}\mathbf{i}_2 + u_3^{(i)}\mathbf{i}_3, \tag{39b}$$

and the relative displacement vector \mathbf{U} with respect to the deformed local coordinate system $\xi-\eta-\zeta$ is given by :

$$\mathbf{U} = u_1^{(i)}\mathbf{i}_1 + u_2^{(i)}\mathbf{i}_2 + u_3^{(i)}\mathbf{i}_3. \tag{39c}$$

4.1. Elastic energy

Variations of the unit vectors of the $\xi-\eta-\zeta$ coordinate system are due to rigid-body rotations, which are given by :

$$\begin{Bmatrix} \delta \mathbf{i}_1 \\ \delta \mathbf{i}_2 \\ \delta \mathbf{i}_3 \end{Bmatrix} = \begin{bmatrix} 0 & \delta \theta_3 & -\delta \theta_2 \\ -\delta \theta_3 & 0 & \delta \theta_1 \\ \delta \theta_2 & -\delta \theta_1 & 0 \end{bmatrix} \begin{Bmatrix} \mathbf{i}_1 \\ \mathbf{i}_2 \\ \mathbf{i}_3 \end{Bmatrix}, \tag{40a}$$

and hence

$$\begin{Bmatrix} \delta\theta_1 \\ \delta\theta_2 \\ \delta\theta_3 \end{Bmatrix} = \begin{Bmatrix} \mathbf{i}_3 \cdot \delta\mathbf{i}_2 \\ \mathbf{i}_1 \cdot \delta\mathbf{i}_3 \\ \mathbf{i}_2 \cdot \delta\mathbf{i}_1 \end{Bmatrix} = \begin{Bmatrix} T_{31}\delta T_{21} + T_{32}\delta T_{22} + T_{33}\delta T_{23} \\ T_{11}\delta T_{31} + T_{12}\delta T_{32} + T_{13}\delta T_{33} \\ T_{21}\delta T_{11} + T_{22}\delta T_{12} + T_{23}\delta T_{13} \end{Bmatrix}, \quad (40b)$$

where $\delta\theta_1$, $\delta\theta_2$ and $\delta\theta_3$ are virtual rigid-body rotations with respect to the ξ , η and ζ axes, respectively. We note that the $\delta\theta_i$ are infinitesimal rotations and hence they are vector quantities. Moreover, the $\delta\theta_i$ are along three perpendicular directions and hence they are mutually independent.

It follows from eqns (39c), (26), (12), (13), (21), (29d) and (29e) that

$$\begin{aligned} \frac{\partial \mathbf{U}}{\partial x} &= \frac{\partial u_1^{(i)}}{\partial x} \mathbf{i}_1 + \frac{\partial u_2^{(i)}}{\partial x} \mathbf{i}_2 + \frac{\partial u_3^{(i)}}{\partial x} \mathbf{i}_3 + u_1^{(i)} \frac{\partial \mathbf{i}_1}{\partial x} + u_2^{(i)} \frac{\partial \mathbf{i}_2}{\partial x} + u_3^{(i)} \frac{\partial \mathbf{i}_3}{\partial x} \\ &= [e_1 + z\kappa_1 + \gamma_{5x}g_{15}^{(i)} + \gamma_{4x}g_{14}^{(i)}] \mathbf{i}_1 + \left[\frac{\partial u_2^{(i)}}{\partial x} + z\kappa_{61} + \gamma_{4x}g_{24}^{(i)} + \gamma_{5x}g_{25}^{(i)} \right] \mathbf{i}_2 \\ &\quad + (\gamma_5 g_{15}^{(i)} + \gamma_4 g_{14}^{(i)}) (-\kappa_1 \mathbf{i}_3 + \kappa_5 \mathbf{i}_2) - (\gamma_4 g_{24}^{(i)} + \gamma_5 g_{25}^{(i)}) (\kappa_6 \mathbf{i}_3 + \kappa_5 \mathbf{i}_1), \end{aligned} \quad (41a)$$

$$\begin{aligned} \frac{\partial \mathbf{U}}{\partial y} &= \frac{\partial u_1^{(i)}}{\partial y} \mathbf{i}_1 + \frac{\partial u_2^{(i)}}{\partial y} \mathbf{i}_2 + \frac{\partial u_3^{(i)}}{\partial y} \mathbf{i}_3 + u_1^{(i)} \frac{\partial \mathbf{i}_1}{\partial y} + u_2^{(i)} \frac{\partial \mathbf{i}_2}{\partial y} + u_3^{(i)} \frac{\partial \mathbf{i}_3}{\partial y} \\ &= \left[\frac{\partial u_1^{(i)}}{\partial y} + z\kappa_{62} + \gamma_{5y}g_{15}^{(i)} + \gamma_{4y}g_{14}^{(i)} \right] \mathbf{i}_1 + [e_2 + z\kappa_2 + \gamma_{4y}g_{24}^{(i)} + \gamma_{5y}g_{25}^{(i)}] \mathbf{i}_2 \\ &\quad + (\gamma_5 g_{15}^{(i)} + \gamma_4 g_{14}^{(i)}) (-\kappa_6 \mathbf{i}_3 + \kappa_4 \mathbf{i}_2) - (\gamma_4 g_{24}^{(i)} + \gamma_5 g_{25}^{(i)}) (\kappa_2 \mathbf{i}_3 + \kappa_4 \mathbf{i}_1), \end{aligned} \quad (41b)$$

$$\begin{aligned} \frac{\partial \mathbf{U}}{\partial z} &= \frac{\partial u_1^{(i)}}{\partial z} \mathbf{i}_1 + \frac{\partial u_2^{(i)}}{\partial z} \mathbf{i}_2 + \frac{\partial u_3^{(i)}}{\partial z} \mathbf{i}_3 \\ &= (\gamma_5 g_{15z}^{(i)} + \gamma_4 g_{14z}^{(i)}) \mathbf{i}_1 + (\gamma_4 g_{24z}^{(i)} + \gamma_5 g_{25z}^{(i)}) \mathbf{i}_2. \end{aligned} \quad (41c)$$

Substituting eqns (41) into eqn (38b) and using the fact that virtual rotations of the coordinate system do not affect the elastic energy, we obtain:

$$\delta V = \sum_{i=1}^N \int_{z_i}^{z_{i+1}} \int_A (\sigma_{11}^{(i)} \delta \varepsilon_{11}^{(i)} + \sigma_{22}^{(i)} \delta \varepsilon_{22}^{(i)} + \sigma_{12}^{(i)} \delta \varepsilon_{12}^{(i)} + \sigma_{23}^{(i)} \delta \varepsilon_{23}^{(i)} + \sigma_{13}^{(i)} \delta \varepsilon_{13}^{(i)}) dx dy dz, \quad (42)$$

where

$$\varepsilon_{11}^{(i)} \equiv \frac{\partial \mathbf{U}}{\partial x} \cdot \mathbf{i}_1 = \varepsilon_{11}^{(i)} - \kappa_5 (\gamma_4 g_{24}^{(i)} + \gamma_5 g_{25}^{(i)}), \quad (43a)$$

$$\varepsilon_{22}^{(i)} \equiv \frac{\partial \mathbf{U}}{\partial y} \cdot \mathbf{i}_2 = \varepsilon_{22}^{(i)} + \kappa_4 (\gamma_5 g_{15}^{(i)} + \gamma_4 g_{14}^{(i)}), \quad (43b)$$

$$\varepsilon_{12}^{(i)} \equiv \frac{\partial \mathbf{U}}{\partial x} \cdot \mathbf{i}_2 + \frac{\partial \mathbf{U}}{\partial y} \cdot \mathbf{i}_1 = \varepsilon_{12}^{(i)} - \kappa_4 (\gamma_4 g_{24}^{(i)} + \gamma_5 g_{25}^{(i)}) + \kappa_5 (\gamma_5 g_{15}^{(i)} + \gamma_4 g_{14}^{(i)}), \quad (43c)$$

$$\varepsilon_{23}^{(i)} \equiv \frac{\partial \mathbf{U}}{\partial z} \cdot \mathbf{i}_2 + \frac{\partial \mathbf{U}}{\partial y} \cdot \mathbf{i}_3 = \varepsilon_{23}^{(i)} - \kappa_2 (\gamma_4 g_{24}^{(i)} + \gamma_5 g_{25}^{(i)}) - \kappa_{62} (\gamma_5 g_{15}^{(i)} + \gamma_4 g_{14}^{(i)}), \quad (43d)$$

$$\varepsilon_{13}^{(i)} \equiv \frac{\partial \mathbf{U}}{\partial z} \cdot \mathbf{i}_1 + \frac{\partial \mathbf{U}}{\partial x} \cdot \mathbf{i}_3 = \varepsilon_{13}^{(i)} - \kappa_{61} (\gamma_4 g_{24}^{(i)} + \gamma_5 g_{25}^{(i)}) - \kappa_1 (\gamma_5 g_{15}^{(i)} + \gamma_4 g_{14}^{(i)}). \quad (43e)$$

Comparing the two strain expressions shown in eqns (28) and (43), we note that the nonlinear terms in eqns (43) are due to the shear rotations γ_4 and γ_5 and the rotation of the coordinate system.

Next, we determine variations of the curvatures κ_i . It follows from eqns (14)–(19), (12), (13) and (40a) that:

$$\int_A m \delta \kappa_1 \, dx \, dy = \int_A \left(m \kappa_5 \delta \theta_1 - \frac{\partial m}{\partial x} \delta \theta_2 + m \kappa_{61} \delta \theta_3 \right) dx \, dy + \int_y m \delta \theta_2 \Big|_{x=0}^{x=a} dy, \quad (44a)$$

$$\int_A m \delta \kappa_2 \, dx \, dy = \int_A \left(\frac{\partial m}{\partial y} \delta \theta_1 + m \kappa_4 \delta \theta_2 - m \kappa_{62} \delta \theta_3 \right) dx \, dy - \int_x m \delta \theta_1 \Big|_{y=0}^{y=b} dx, \quad (44b)$$

$$\int_A m \delta \kappa_{61} \, dx \, dy = \int_A \left(\frac{\partial m}{\partial x} \delta \theta_1 + m \kappa_5 \delta \theta_2 - m \kappa_1 \delta \theta_3 \right) dx \, dy - \int_y m \delta \theta_1 \Big|_{x=0}^{x=a} dy, \quad (44c)$$

$$\int_A m \delta \kappa_{62} \, dx \, dy = \int_A \left(m \kappa_4 \delta \theta_1 - \frac{\partial m}{\partial y} \delta \theta_2 + m \kappa_2 \delta \theta_3 \right) dx \, dy + \int_x m \delta \theta_2 \Big|_{y=0}^{y=b} dx, \quad (44d)$$

$$\int_A m \delta \kappa_4 \, dx \, dy = \int_A \left(-m \kappa_{62} \delta \theta_1 - m \kappa_2 \delta \theta_2 - \frac{\partial m}{\partial y} \delta \theta_3 \right) dx \, dy + \int_x m \delta \theta_3 \Big|_{y=0}^{y=b} dx, \quad (44e)$$

$$\int_A m \delta \kappa_5 \, dx \, dy = \int_A \left(-m \kappa_1 \delta \theta_1 - m \kappa_{61} \delta \theta_2 - \frac{\partial m}{\partial x} \delta \theta_3 \right) dx \, dy + \int_y m \delta \theta_3 \Big|_{x=0}^{x=a} dy, \quad (44f)$$

where m represents any stress resultant or moment; they are defined in Appendix A.

Substituting eqns (44) into eqn (42), we obtain the virtual elastic energy in terms of the stress resultants, stress moments, and inplane strains as:

$$\begin{aligned} \delta V = & \int_A (N_1 \delta e_1 + N_2 \delta e_2 + N_6 \delta \gamma_6 + \Theta_1 \delta \theta_1 + \Theta_2 \delta \theta_2 + \Theta_3 \delta \theta_3 + \Gamma_4 \delta \gamma_4 + \Gamma_5 \delta \gamma_5) \, dx \, dy \\ & + \int_x [-\hat{M}_2 \delta \theta_1 + \hat{M}_{62} \delta \theta_2 + m_{32} \delta \theta_3 + m_2 \delta \gamma_4 + m_{62} \delta \gamma_5] \Big|_{y=0}^{y=b} dx \\ & + \int_y [-\hat{M}_{61} \delta \theta_1 + \hat{M}_1 \delta \theta_2 + m_{31} \delta \theta_3 + m_{61} \delta \gamma_4 + m_1 \delta \gamma_5] \Big|_{x=0}^{x=a} dy, \end{aligned} \quad (45)$$

where

$$\hat{M}_1 \equiv M_1 - \bar{s}_{11} \gamma_5 - \bar{s}_{11} \gamma_4, \quad (46a)$$

$$\hat{M}_2 \equiv M_2 - \bar{s}_{22} \gamma_5 - \bar{s}_{22} \gamma_4, \quad (46b)$$

$$\hat{M}_{61} \equiv M_6 - \bar{s}_{12} \gamma_5 - \bar{s}_{12} \gamma_4, \quad (46c)$$

$$\hat{M}_{62} \equiv M_6 - \bar{s}_{21} \gamma_5 - \bar{s}_{21} \gamma_4, \quad (46d)$$

$$m_{31} \equiv (\bar{m}_{62} - \bar{m}_1) \gamma_5 + (\bar{m}_{62} - \bar{m}_1) \gamma_4, \quad (46e)$$

$$m_{32} \equiv (\bar{m}_2 - \bar{m}_{61}) \gamma_5 + (\bar{m}_2 - \bar{m}_{61}) \gamma_4, \quad (46f)$$

$$\Theta_1 \equiv \hat{M}_{61x} + \hat{M}_{2y} - m_{31} \kappa_1 - m_{32} \kappa_{62} + \hat{M}_1 \kappa_5 + \hat{M}_{62} \kappa_4, \quad (46g)$$

$$\Theta_2 \equiv -\hat{M}_{1x} - \hat{M}_{62y} - m_{31} \kappa_{61} - m_{32} \kappa_2 + \hat{M}_2 \kappa_4 + \hat{M}_{61} \kappa_5, \quad (46h)$$

$$\Theta_3 \equiv -m_{31x} - m_{32y} + \hat{M}_1 \kappa_{61} - \hat{M}_2 \kappa_{62} + \hat{M}_{62} \kappa_2 - \hat{M}_{61} \kappa_1, \quad (46i)$$

$$\Gamma_4 \equiv -m_{61x} - m_{2y} + q_2 - \bar{s}_{11}\kappa_1 - \bar{s}_{22}\kappa_2 - \bar{s}_{12}\kappa_{61} - \bar{s}_{21}\kappa_{62} \\ + (\bar{m}_2 - \bar{m}_{61})\kappa_4 + (\bar{m}_{62} - \bar{m}_1)\kappa_5, \quad (46j)$$

$$\Gamma_5 \equiv -m_{1x} - m_{62y} + q_1 - \bar{s}_{11}\kappa_1 - \bar{s}_{22}\kappa_2 - \bar{s}_{12}\kappa_{61} - \bar{s}_{21}\kappa_{62} \\ + (\bar{m}_2 - \bar{m}_{61})\kappa_4 + (\bar{m}_{62} - \bar{m}_1)\kappa_5. \quad (46k)$$

Here, \hat{M}_1 , \hat{M}_2 , \hat{M}_{61} , \hat{M}_{62} , m_{31} and m_{32} represent the total moment intensities (Pai and Nayfeh, 1991) acting on the edges of the plate element. Equations (46) show that m_{31} , m_{32} and Θ_3 are nonlinear terms. We note that the effects of κ_4 and κ_5 are nonlinear. It can be seen from eqns (42) and (43) that if changes in the elastic energy due to changes in the configuration are not included (i.e. the ε_{ij} are used instead of the $\hat{\varepsilon}_{ij}$) and linear curvature expressions are used, then there are no nonlinear terms in eqns (46) and $m_{31} = m_{32} = \Theta_3 = 0$.

It follows from Fig. 2(b) and transformation theory that the relations between the axial strains e_1 and e_2 and the displacements are:

$$1 + e_1 = T_{11}(1 + u_x) + T_{12}v_x + T_{13}w_x, \quad (47a)$$

$$1 + e_2 = T_{21}u_y + T_{22}(1 + v_y) + T_{23}w_y. \quad (47b)$$

Taking the variation of eqns (47) and using eqns (5) and (6), we obtain:

$$\delta e_1 = T_{11}\delta u_x + T_{12}\delta v_x + T_{13}\delta w_x, \quad (48a)$$

$$\delta e_2 = T_{21}\delta u_y + T_{22}\delta v_y + T_{23}\delta w_y. \quad (48b)$$

It follows from eqns (3)–(6) that:

$$\delta \mathbf{i}_1 = \frac{1}{1 + e_1} (\delta u_x \mathbf{i}_x + \delta v_x \mathbf{i}_y + \delta w_x \mathbf{i}_z) - \frac{\delta e_1}{1 + e_1} \mathbf{i}_1, \quad (49a)$$

$$\delta \mathbf{i}_2 = \frac{1}{1 + e_2} [\delta u_y \mathbf{i}_x + \delta v_y \mathbf{i}_y + \delta w_y \mathbf{i}_z] - \frac{\delta e_2}{1 + e_2} \mathbf{i}_2. \quad (49b)$$

Using eqns (49), (8) and (40b), one can show that:

$$(1 + e_1)\delta\theta_2 + T_{31}\delta u_x + T_{32}\delta v_x + T_{33}\delta w_x = 0, \quad (50a)$$

$$-(1 + e_2)\delta\theta_1 + T_{31}\delta u_y + T_{32}\delta v_y + T_{33}\delta w_y = 0. \quad (50b)$$

It can be seen from Fig. 2(b) that:

$$\delta\gamma_{61} = \delta \mathbf{i}_1 \cdot \mathbf{i}_2, \quad \delta\gamma_{62} = \delta \mathbf{i}_2 \cdot \mathbf{i}_1, \quad (51)$$

where $\gamma_{61} = \gamma_{62} = \gamma_6/2$. Using eqns (49) and the relations $\mathbf{i}_1 = \mathbf{i}_{\bar{1}}$ and $\mathbf{i}_2 = \mathbf{i}_{\bar{2}}$ (i.e. neglect the influence of γ_6 on the change of plate configuration), one can show that:

$$\delta\gamma_6 = \frac{1}{1 + e_1} (T_{21}\delta u_x + T_{22}\delta v_x + T_{23}\delta w_x) + \frac{1}{1 + e_2} (T_{11}\delta u_y + T_{12}\delta v_y + T_{13}\delta w_y). \quad (52)$$

Substituting eqns (48), (50) and (52) into eqn (45), we obtain:

$$\begin{aligned}
 \delta V = & \int_A [\{N_1, N_6/(1+e_1), -\Theta_2/(1+e_1)\}[T] \begin{Bmatrix} \delta u_x \\ \delta v_x \\ \delta w_x \end{Bmatrix} \\
 & + \{N_6/(1+e_2), N_2, \Theta_1/(1+e_2)\}[T] \begin{Bmatrix} \delta u_y \\ \delta v_y \\ \delta w_y \end{Bmatrix} + \Theta_3 \delta \theta_3 + \Gamma_4 \delta \gamma_4 + \Gamma_5 \delta \gamma_5 \delta \gamma_5] dx dy \\
 & + \int_x [-\hat{M}_2 \delta \theta_1 + \hat{M}_{62} \delta \theta_2 + m_{32} \delta \theta_3 + m_2 \delta \gamma_4 + m_{62} \delta \gamma_5]_{y=0}^b dx \\
 & + \int_y [-\hat{M}_{61} \delta \theta_1 + \hat{M}_1 \delta \theta_2 + m_{31} \delta \theta_3 + m_{61} \delta \gamma_4 + m_1 \delta \gamma_5]_{x=0}^a dy. \tag{53}
 \end{aligned}$$

4.2. Kinetic energy

Substituting eqns (26) and (21) into eqn (39b) yields:

$$\mathbf{D} = u\mathbf{i}_x + v\mathbf{i}_y + w\mathbf{i}_z + z\mathbf{i}_3 - z\mathbf{i}_z + (\gamma_5 g_{15}^{(i)} + \gamma_4 g_{14}^{(i)})\mathbf{i}_1 + (\gamma_4 g_{24}^{(i)} + \gamma_5 g_{25}^{(i)})\mathbf{i}_2. \tag{54}$$

Because the rigid-body rotation of the $\xi-\eta-\zeta$ coordinate system results in the main part of the rotational kinetic energy (the other part of the rotational kinetic energy is due to shear rotations), we need to account for the virtual kinetic energies due to the virtual rotations of the coordinate system, which are $\delta\mathbf{i}_1$, $\delta\mathbf{i}_2$ and $\delta\mathbf{i}_3$, as shown in eqn (40a). Taking the variation and the time derivative of eqn (54), we obtain:

$$\begin{aligned}
 \delta \mathbf{D} = & \mathbf{i}_x \delta u + \mathbf{i}_y \delta v + \mathbf{i}_z \delta w + (g_{14}^{(i)} \mathbf{i}_1 + g_{24}^{(i)} \mathbf{i}_2) \delta \gamma_4 + (g_{15}^{(i)} \mathbf{i}_1 + g_{25}^{(i)} \mathbf{i}_2) \delta \gamma_5 \\
 & + [(\gamma_4 g_{24}^{(i)} + \gamma_5 g_{25}^{(i)}) \mathbf{i}_3 - z \mathbf{i}_2] \delta \theta_1 + [z \mathbf{i}_1 - (\gamma_5 g_{15}^{(i)} + \gamma_4 g_{14}^{(i)}) \mathbf{i}_3] \delta \theta_2 \\
 & + [(\gamma_5 g_{15}^{(i)} + \gamma_4 g_{14}^{(i)}) \mathbf{i}_2 - (\gamma_4 g_{24}^{(i)} + \gamma_5 g_{25}^{(i)}) \mathbf{i}_1] \delta \theta_3 \tag{55a}
 \end{aligned}$$

and

$$\begin{aligned}
 \dot{\mathbf{D}} = & \ddot{u}\mathbf{i}_x + \ddot{v}\mathbf{i}_y + \ddot{w}\mathbf{i}_z + z\ddot{\mathbf{i}}_3 + (\ddot{\gamma}_5 g_{15}^{(i)} + \ddot{\gamma}_4 g_{14}^{(i)})\mathbf{i}_1 + 2(\dot{\gamma}_5 g_{15}^{(i)} + \dot{\gamma}_4 g_{14}^{(i)})\dot{\mathbf{i}}_1 + (\gamma_5 g_{15}^{(i)} + \gamma_4 g_{14}^{(i)})\ddot{\mathbf{i}}_1 \\
 & + (\ddot{\gamma}_4 g_{24}^{(i)} + \ddot{\gamma}_5 g_{25}^{(i)})\mathbf{i}_2 + 2(\dot{\gamma}_4 g_{24}^{(i)} + \dot{\gamma}_5 g_{25}^{(i)})\dot{\mathbf{i}}_2 + (\gamma_4 g_{24}^{(i)} + \gamma_5 g_{25}^{(i)})\ddot{\mathbf{i}}_2, \tag{55b}
 \end{aligned}$$

where the dot denotes differentiation with respect to time and

$$\begin{aligned}
 \mathbf{i}_k &= T_{k1}\mathbf{i}_x + T_{k2}\mathbf{i}_y + T_{k3}\mathbf{i}_z, \\
 \dot{\mathbf{i}}_k &= \dot{T}_{k1}\mathbf{i}_x + \dot{T}_{k2}\mathbf{i}_y + \dot{T}_{k3}\mathbf{i}_z, \\
 \ddot{\mathbf{i}}_k &= \ddot{T}_{k1}\mathbf{i}_x + \ddot{T}_{k2}\mathbf{i}_y + \ddot{T}_{k3}\mathbf{i}_z, \tag{55c}
 \end{aligned}$$

for $k = 1, 2, 3$. Using eqns (55) and the identity $\mathbf{i}_k \cdot \mathbf{i}_k = 0$ in eqn (38a), we obtain

$$\delta T = - \int_A (A_u \delta u + A_v \delta v + A_w \delta w + A_{\gamma_4} \delta \gamma_4 + A_{\gamma_5} \delta \gamma_5 + A_{\theta_1} \delta \theta_1 + A_{\theta_2} \delta \theta_2 + A_{\theta_3} \delta \theta_3) dx dy, \tag{56}$$

where the inertial terms $A_u, A_v, A_w, A_{\gamma_4}, A_{\gamma_5}, A_{\theta_1}, A_{\theta_2}$ and A_{θ_3} are given in Appendix B.

4.3. Equations of motion

Substituting eqns (50), (56) and (53) into eqn (37), integrating the terms in eqn (37) by parts, and then setting each of the coefficients of $\delta u, \delta v, \delta w, \delta \gamma_4$ and $\delta \gamma_5$ equal to zero,

we obtain the following equations of motion :

$$F_{11x} + F_{12y} = A_u + \mu_1 \dot{u}, \quad (57a)$$

$$F_{21x} + F_{22y} = A_v + \mu_2 \dot{v}, \quad (57b)$$

$$F_{31x} + F_{32y} = A_w + \mu_3 \dot{w}, \quad (57c)$$

$$m_{61x} + m_{2y} - q_2 + \bar{s}_{11}\kappa_1 + \bar{s}_{22}\kappa_2 + \bar{s}_{12}\kappa_{61} + \bar{s}_{21}\kappa_{62} \\ - (\bar{m}_2 - \bar{m}_{61})\kappa_4 - (\bar{m}_{62} - \bar{m}_1)\kappa_5 = A_{\gamma_4} + \mu_4 \dot{\gamma}_4, \quad (57d)$$

$$m_{1x} + m_{62y} - q_1 + \bar{s}_{11}\kappa_1 + \bar{s}_{22}\kappa_2 + \bar{s}_{12}\kappa_{61} + \bar{s}_{21}\kappa_{62} \\ - (\bar{m}_2 - \bar{m}_{61})\kappa_4 - (\bar{m}_{62} - \bar{m}_1)\kappa_5 = A_{\gamma_5} + \mu_5 \dot{\gamma}_5, \quad (57e)$$

where

$$\{F_{11}, F_{21}, F_{31}\} = \{N_1, N_6/(1+e_1), -\bar{\Theta}_2/(1+e_1)\}[T], \\ \{F_{12}, F_{22}, F_{32}\} = \{N_6/(1+e_2), N_2, \bar{\Theta}_1/(1+e_2)\}[T], \\ \bar{\Theta}_1 \equiv \Theta_1 + A_{\theta_1}, \\ \bar{\Theta}_2 \equiv \Theta_2 + A_{\theta_2}. \quad (58)$$

We added a linear viscous damping term to each of eqns (57), where the μ_i are the damping coefficients. The boundary conditions for the plate are of the form :

Along $x = 0, x = a$:

$$\delta u = 0, \quad F_{11} + [\hat{M}_{61}T_{31}/(1+e_2)]_y, \\ \delta v = 0, \quad F_{21} + [\hat{M}_{61}T_{32}/(1+e_2)]_y, \\ \delta w = 0, \quad F_{31} + [\hat{M}_{61}T_{33}/(1+e_2)]_y, \\ \delta\theta_2 = 0, \quad \hat{M}_1, \\ \delta\gamma_4 = 0, \quad m_{61}, \\ \delta\gamma_5 = 0, \quad m_1; \quad (59a)$$

Along $y = 0, y = b$:

$$\delta u = 0, \quad F_{12} + [\hat{M}_{62}T_{31}/(1+e_1)]_x, \\ \delta v = 0, \quad F_{22} + [\hat{M}_{62}T_{32}/(1+e_1)]_x, \\ \delta w = 0, \quad F_{32} + [\hat{M}_{62}T_{33}/(1+e_1)]_x, \\ \delta\theta_1 = 0, \quad \hat{M}_2, \\ \delta\gamma_4 = 0, \quad m_2, \\ \delta\gamma_5 = 0, \quad m_{62}; \quad (59b)$$

At $(x, y) = (0, 0), (a, 0), (0, b), (a, b)$:

$$\delta u = 0, \quad -T_{31}[\hat{M}_{62}/(1+e_1) + \hat{M}_{61}/(1+e_2)], \\ \delta v = 0, \quad -T_{32}[\hat{M}_{62}/(1+e_1) + \hat{M}_{61}/(1+e_2)], \\ \delta w = 0, \quad -T_{33}[\hat{M}_{62}/(1+e_1) + \hat{M}_{61}/(1+e_2)]. \quad (59c)$$

The corner conditions for u and v are nonlinear as can be seen from eqn (59c). The stress

resultants and moments which include piezoelectric actuating forces are separated into two parts: one is due to deformations (indicated by superscript d) and the other one is due to actuating forces (indicated by superscript f). The result is:

$$\begin{aligned} & \{N_1, N_2, N_6, M_1, M_2, M_6, m_{61}, m_2, m_1, m_{62}\} \\ & \equiv \{N_1^d, N_2^d, N_6^d, M_1^d, M_2^d, M_6^d, m_{61}^d, m_2^d, m_1^d, m_{62}^d\} \\ & - L\{N_1^f, N_2^f, N_6^f, M_1^f, M_2^f, M_6^f, m_{61}^f, m_2^f, m_1^f, m_{62}^f\}, \end{aligned} \tag{60a}$$

$$\begin{aligned} & \{\bar{m}_1, \bar{m}_1, \bar{m}_2, \bar{m}_2, \bar{m}_{62}, \bar{m}_{62}, \bar{m}_{61}, \bar{m}_{61}\} \\ & \equiv \{\bar{m}_1^d, \bar{m}_1^d, \bar{m}_2^d, \bar{m}_2^d, \bar{m}_{62}^d, \bar{m}_{62}^d, \bar{m}_{61}^d, \bar{m}_{61}^d\} \\ & - L\{\bar{m}_1^f, \bar{m}_1^f, \bar{m}_2^f, \bar{m}_2^f, \bar{m}_{62}^f, \bar{m}_{62}^f, \bar{m}_{61}^f, \bar{m}_{61}^f\}, \end{aligned} \tag{60b}$$

where

$$\begin{aligned} \{N_1^d, N_2^d, N_6^d, M_1^d, M_2^d, M_6^d, m_{61}^d, m_2^d, m_1^d, m_{62}^d\} & \equiv \{\psi\}^T \sum_{i=1}^N \int_{z_i}^{z_{i+1}} [S^{(i)}]^T [\bar{Q}^{(i)}] [S^{(i)}] dz, \\ \{N_1^f, N_2^f, N_6^f, M_1^f, M_2^f, M_6^f, m_{61}^f, m_2^f, m_1^f, m_{62}^f\} & \equiv \{\bar{\Lambda}_1, \bar{\Lambda}_2, \bar{\Lambda}_{12}\} \int_{z_i}^{z_{i+1}} [\bar{Q}^{(i)}] [S^{(i)}] dz, \end{aligned} \tag{61a}$$

$$\begin{aligned} \{\bar{m}_1^d, \bar{m}_1^d, \bar{m}_2^d, \bar{m}_2^d, \bar{m}_{62}^d, \bar{m}_{62}^d, \bar{m}_{61}^d, \bar{m}_{61}^d\} & \equiv \{\psi\}^T \sum_{i=1}^N \int_{z_i}^{z_{i+1}} [S^{(i)}]^T [\bar{Q}^{(i)}] [S_3^{(i)}] dz, \\ \{\bar{m}_1^f, \bar{m}_1^f, \bar{m}_2^f, \bar{m}_2^f, \bar{m}_{62}^f, \bar{m}_{62}^f, \bar{m}_{61}^f, \bar{m}_{61}^f\} & \equiv \{\bar{\Lambda}_1, \bar{\Lambda}_2, \bar{\Lambda}_{12}\} \int_{z_i}^{z_{i+1}} [\bar{Q}^{(i)}] [S_3^{(i)}] dz. \end{aligned} \tag{61b}$$

Because the rotary inertia A_{θ_3} about the ζ -axis is due to nonlinear effects [see eqn (B12)] and is usually negligible,

$$\Theta_3 + A_{\theta_3} = 0, \tag{62a}$$

$$m_{31} = 0 \quad \text{along } x = 0 \quad \text{and } x = a, \tag{62b}$$

$$m_{32} = 0 \quad \text{along } y = 0 \quad \text{and } y = b, \tag{62c}$$

is a statement of the balance of the internal moments with respect to the ζ -axis, which has no significant influence on the plate dynamics.

5. DISCUSSIONS AND COMPARISONS

5.1. Warping functions

For isotropic plates or one-layer orthotropic plates with an arbitrary ply angle, the external-load-induced warping functions are:

$$g_{13}^{(i)} = g_{24}^{(i)} = z - \frac{4z^3}{3h^2} \quad \text{and} \quad g_{14}^{(i)} = g_{23}^{(i)} = 0. \tag{63}$$

Thus, there is no coupling between the two transverse shear rotations γ_4 and γ_5 . This is the so-called third-order shear–deformation theory (Reddy, 1984; Bhimaraddi and Stevens, 1984). However, for general laminated plates, $g_{14}^{(i)}$ and $g_{23}^{(i)}$ are nontrivial and hence γ_4 and γ_5 are coupled. In Figs 5(a), (b), (c) and (d), we show the external-load-induced warping functions for a five-layer graphite-epoxy laminated composite plate with the layups $[10^\circ/5^\circ/0^\circ/5^\circ/10^\circ]$, $[10^\circ/5^\circ/0^\circ/-5^\circ/-10^\circ]$, $[60^\circ/30^\circ/0^\circ/30^\circ/60^\circ]$ and $[60^\circ/0^\circ/-30^\circ/20^\circ/10^\circ]$.

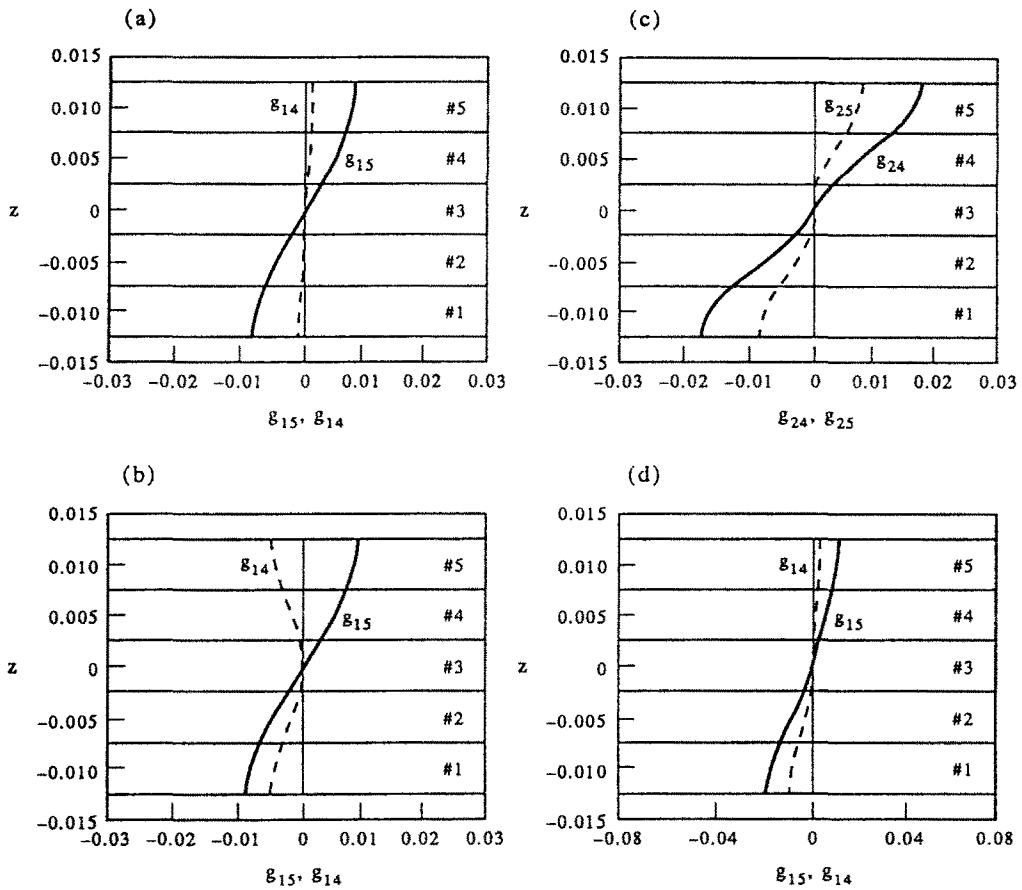

Fig. 5. External-load-induced warpings: (a) $[10^\circ/5^\circ/0^\circ/5^\circ/10^\circ]$, (b) $[10^\circ/5^\circ/0^\circ/-5^\circ/-10^\circ]$, (c) $[60^\circ/30^\circ/0^\circ/30^\circ/60^\circ]$, and (d) $[60^\circ/0^\circ/-30^\circ/20^\circ/10^\circ]$.

respectively. The material properties of each lamina are:

$$\begin{aligned}
 E_1 &= 1.92 \times 10^7 \text{ psi}, & E_2 = E_3 &= 1.56 \times 10^6 \text{ psi}, \\
 G_{23} &= 5.23 \times 10^5 \text{ psi}, & G_{12} = G_{13} &= 8.20 \times 10^5 \text{ psi}, \\
 \nu_{12} = \nu_{13} &= 0.24, & \nu_{23} &= 0.49,
 \end{aligned}
 \tag{64a}$$

and the lamina thickness $t_k = 0.005$ in. It follows from Figs 5(a) and 5(b) that antisymmetric lamination results in even shear coupling functions $g_{14}^{(i)}$ and $g_{25}^{(i)}$ whereas symmetric lamination results in odd shear coupling functions. Moreover, antisymmetric lamination results in more significant shear coupling effects. It follows from Fig. 5(c) that, for a symmetric laminate with large ply angles, the warping functions $g_{15}^{(i)}$ and $g_{24}^{(i)}$ are quite different from those used in the third-order shear theory. Moreover, it follows from Fig. 5(d) that, for a general laminated plate, the warping functions $g_{15}^{(i)}$ and $g_{24}^{(i)}$ are not odd functions and the shear coupling functions $g_{14}^{(i)}$ and $g_{25}^{(i)}$ are neither odd nor even functions.

In Fig. 6, we show the actuator-induced warping functions for a three-layer laminate with the second layer being an actuator. The passive layers are aluminum with the properties:

$$E = 1.03 \times 10^7 \text{ psi} \quad \text{and} \quad \nu = 0.334;
 \tag{64b}$$

and the piezoelectric actuator is an isotropic G-1195 piezoelectric patch (Piezo System, 1987) with the properties:

$$E = 9.14 \times 10^6 \text{ psi} \quad \text{and} \quad \nu = 0.28.
 \tag{64c}$$

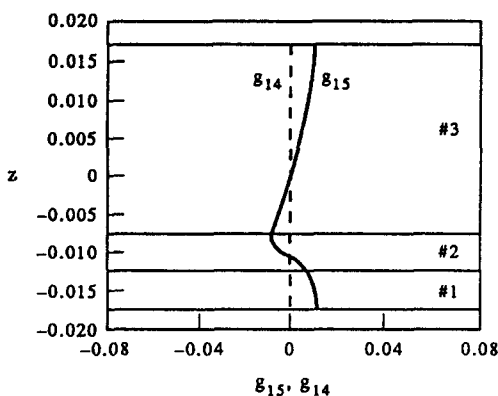

Fig. 6. Actuator-induced warping functions of an aluminum-piezoceramic-aluminum laminate.

Because both the actuator and substrate are isotropic, there are no shear couplings (i.e. $g_{14}^{(i)} = g_{25}^{(i)} = 0$) and $g_{15}^{(i)} = g_{24}^{(i)}$.

In Figs 7(a) and 7(b), we show the actuator-induced warping functions for a seven-layer laminate with the second layer being an actuator and the layup being $[10^\circ/0^\circ/20^\circ/40^\circ/-30^\circ/90^\circ/45^\circ]$. The material properties of the composite laminae and the actuator are given by eqns (64a) and (64c), respectively. We note that, in this case, there are shear couplings and the warping functions are very different from those of isotropic plates and depend on the stacking sequence. We point out that the actuator-induced

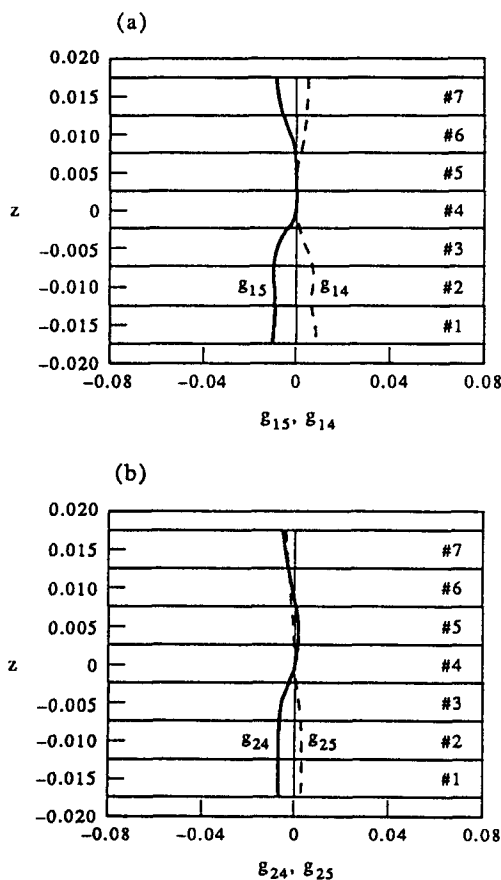

Fig. 7. Actuator-induced warping functions of a graphy-epoxy laminate where the layup is $[10^\circ/0^\circ/20^\circ/40^\circ/-30^\circ/90^\circ/45^\circ]$: (a) g_{15} and g_{14} , and (b) g_{24} and g_{25} .

extension of the reference plane and the bending rotations are not included in the warping functions because the warping functions represent displacements with respect to the deformed local coordinate system.

5.2. Classical plate theory with von Karman nonlinearities

In the classical plate theory, it is assumed that normals to the midplane before deformation remain straight and normal to the midplane after deformation, which implies that :

$$\varepsilon_{13} = \varepsilon_{23} = \gamma_4 = \gamma_5 = 0. \quad (65)$$

If, furthermore, von Karman strains are used to account for the geometric nonlinearities, then :

$$\{\psi\} = \{\{\hat{\psi}\}^T, 0, 0, 0, 0\}^T, \quad (66a)$$

$$\{\hat{\psi}\} = \{u_x + \frac{1}{2}w_x^2, v_y + \frac{1}{2}w_y^2, u_y + v_x + w_x w_y, -w_{xx}, -w_{yy}, -2w_{xy}\}^T, \quad (66b)$$

and

$$[T] = \begin{bmatrix} 1 & 0 & w_x \\ 0 & 1 & w_y \\ 0 & 0 & 1 \end{bmatrix}, \quad (66c)$$

as shown by Pai and Nayfeh (1991). We note that eqn (66c) can also be obtained using direct geometric considerations. It follows from eqns (65), (66) and (57a-c) that the equations of motion in this case simplify to :

$$N_{1x} + N_{6y} = A_u + \mu_1 \dot{u}, \quad (67a)$$

$$N_{6x} + N_{2y} = A_v + \mu_2 \dot{v}, \quad (67b)$$

$$\begin{aligned} (N_1 w_x + N_6 w_y + M_{1x} + M_{6y})_x + (N_6 w_x + N_2 w_y + M_{6x} + M_{2y})_y \\ = A_w + (A_{\theta_2})_x - (A_{\theta_1})_y + \mu_3 \dot{w}. \end{aligned} \quad (67c)$$

The boundary conditions for the plate are of the form :

Along $x = 0, x = a$:

$$\begin{aligned} \delta u &= 0, & N_1, \\ \delta v &= 0, & N_6, \\ \delta w &= 0, & N_1 w_x + N_6 w_y + M_{1x} + 2M_{6y} - A_{\theta_2}, \\ -\delta w_x &= 0, & M_1; \end{aligned}$$

Along $y = 0, y = b$:

$$\begin{aligned} \delta u &= 0, & N_6, \\ \delta v &= 0, & N_2, \\ \delta w &= 0, & N_6 w_x + N_2 w_y + 2M_{6x} + M_{2y} + A_{\theta_1}, \\ \delta w_y &= 0, & M_2; \end{aligned} \quad (68)$$

At $(x, y) = (0, 0), (0, b), (a, 0), (a, b)$:

$$\delta w = 0, \quad 2M_6.$$

It follows from eqns (A1), (66), (30), (28a), (29a) and (61a) that :

$$\{N_1^d, N_2^d, N_6^d, M_1^d, M_2^d, M_6^d\} \equiv \{\hat{\psi}\}^T \begin{bmatrix} [A] & [B] \\ [B] & [D] \end{bmatrix}, \tag{69a}$$

$$\{N_1^f, N_2^f, N_6^f, M_1^f, M_2^f, M_6^f\} \equiv \{\bar{\Lambda}_1, \bar{\Lambda}_2, \bar{\Lambda}_{12}\} \int_{z_i}^{z_{i+1}} [[\tilde{Q}^{(i)}], z[\tilde{Q}^{(i)}]] dz, \tag{69b}$$

where

$$\begin{bmatrix} [A] & [B] \\ [B] & [D] \end{bmatrix} \equiv \sum_{i=1}^N \int_{z_i}^{z_{i+1}} \begin{bmatrix} [\tilde{Q}^{(i)}] & z[\tilde{Q}^{(i)}] \\ z[\tilde{Q}^{(i)}] & z^2[\tilde{Q}^{(i)}] \end{bmatrix} dz. \tag{69c}$$

5.3. Linear piezoelectric plate theory

Linearizing eqns (57a-e), we obtain the following linear equations of motion for piezoelectric plates :

$$N_{1x}^d + N_{6y}^d - N_1^f L_x - N_6^f L_y = I_0 \ddot{u} - I_1 \ddot{w}_x + I_6 \ddot{\gamma}_5 + I_5 \ddot{\gamma}_4 + \mu_1 \dot{u}, \tag{70a}$$

$$N_{6x}^d + N_{2y}^d - N_6^f L_x - N_2^f L_y = I_0 \ddot{v} - I_1 \ddot{w}_y + I_7 \ddot{\gamma}_4 + I_8 \ddot{\gamma}_5 + \mu_2 \dot{v}, \tag{70b}$$

$$M_{1xx}^d + 2M_{6xy}^d + M_{2yy}^d - M_1^f L_{xx} - 2M_6^f L_{xy} - M_2^f L_{yy} = I_0 \ddot{w} + (I_1 \ddot{u} - I_2 \ddot{w}_x + I_{61} \ddot{\gamma}_5 + I_{51} \ddot{\gamma}_4)_x + (I_1 \ddot{v} - I_2 \ddot{w}_y + I_{71} \ddot{\gamma}_4 + I_{81} \ddot{\gamma}_5)_y + \mu_3 \dot{w}, \tag{70c}$$

$$m_{61x}^d + m_{2y}^d - q_2 - m_{61}^f L_x - m_2^f L_y = (I_{55} + I_{77}) \ddot{\gamma}_4 + (I_{56} + I_{78}) \ddot{\gamma}_5 + I_5 \ddot{u} + I_7 \ddot{v} - I_{51} \ddot{w}_x - I_{71} \ddot{w}_y + \mu_4 \dot{\gamma}_4, \tag{70d}$$

$$m_{1x}^d + m_{62y}^d - q_1 - m_1^f L_x - m_{62}^f L_y = (I_{66} + I_{88}) \ddot{\gamma}_5 + (I_{56} + I_{78}) \ddot{\gamma}_4 + I_6 \ddot{u} + I_8 \ddot{v} - I_{61} \ddot{w}_x - I_{81} \ddot{w}_y + \mu_5 \dot{\gamma}_5, \tag{70e}$$

where the stress resultants are defined in eqn (61a) with :

$$\{\psi\} = \{u_x, v_y, u_y + v_x, -w_{xx}, -w_{yy}, -2w_{xy}, \gamma_{4x}, \gamma_{4y}, \gamma_{5x}, \gamma_{5y}\}^T \tag{71}$$

and

$$\{q_2, q_1\} \equiv \{\gamma_4, \gamma_5\} \sum_{i=1}^N \int_{z_i}^{z_{i+1}} [S_2^{(i)}]^T [\tilde{Q}^{(i)}] [S_2^{(i)}] dz. \tag{72}$$

The corresponding linear boundary conditions are of the form :

Along $x = 0, x = a$:

$$\begin{aligned} \delta u &= 0, & N_1, \\ \delta v &= 0, & N_6, \\ \delta w &= 0, & M_{1x} + 2M_{6y} + I_2 \ddot{w}_x - I_1 \ddot{u} - I_{61} \ddot{\gamma}_5 - I_{51} \ddot{\gamma}_4, \\ -\delta w_x &= 0, & M_1, \\ \delta \gamma_4 &= 0, & m_{61}, \\ \delta \gamma_5 &= 0, & m_1; \end{aligned}$$

Along $y = 0, y = b$:

$$\begin{aligned}
 \delta u &= 0, & N_6, \\
 \delta v &= 0, & N_2, \\
 \delta w &= 0, & 2M_{6x} + M_{2y} + I_2 \ddot{w}_y - I_1 \ddot{v} - I_{71} \ddot{\gamma}_4 - I_{81} \ddot{\gamma}_5, \\
 \delta w_y &= 0, & M_2, \\
 \delta \gamma_4 &= 0, & m_2, \\
 \delta \gamma_5 &= 0, & m_{62};
 \end{aligned} \tag{73}$$

At $(x, y) = (0, 0), (a, 0), (0, b), (a, b)$:

$$\delta w = 0, \quad -2M_6.$$

5.4. Actuator-induced loads

It follows from eqns (A1)–(A5) that all stress resultants and moments are defined with respect to the deformed coordinate system ξ – η – ζ because local stresses are used in their definitions. Moreover, to solve eqns (57a–e) subject to the boundary conditions eqns (59a–c), one needs to evaluate the integral

$$\int_A m^f(L_x, L_y, L_{xx}, L_{xy}, L_{yy}) \, dx \, dy, \tag{74}$$

where m^f denotes either a stress resultant or a moment due to piezoelectric actuation. Because $L(x, y)$ is a Heaviside function [see eqn (33c)], L_x and L_y are given by the Kronecker delta function δ , and L_{xx} , L_{xy} and L_{yy} are given by the derivatives of δ . Hence, induced actuating forces and moments act only along the boundaries of the actuators (Lee, 1990). Because of this discontinuity in the actuating loads, the resulting structural strains are discontinuous, especially around the boundaries of the actuators. Obtaining analytical solutions for such problems by assuming displacement functions which can account for this discontinuity in the strains is almost an impossible task. On the other hand, a numerical approach by using finite-element methods can be used to account for this discontinuity in the strains as well as arbitrarily designed and distributed actuators.

5.5. Thermal and moisture effects

Induced strains due to thermal and moisture expansion or contraction are of the same form as those due to piezoelectric actuation except that the location function $R(x, y, z)$ is not needed because thermal and moisture effects are usually continuously distributed over the whole structure. Hence, the stress–strain relations are the same as those shown in eqns (30) and (32) except that $R = 1$ and

$$\Lambda_1 = \alpha_1 \Delta T, \quad \Lambda_2 = \alpha_2 \Delta T, \tag{75a}$$

in the case of a thermal effect, and

$$\Lambda_1 = \beta_1 \Delta m, \quad \Lambda_2 = \beta_2 \Delta m, \tag{75b}$$

in the case of a moisture effect. Here, the α_i are the coefficients of thermal expansion, ΔT is the temperature change, the β_i are the coefficients of hygrothermal expansion, and Δm is the percentage weight increase due to moisture. Moreover, the definitions of the stress resultants and moments due to induced-strain actuation [see eqns (61)] need to be redefined as:

$$\{N_1^f, N_2^f, N_6^f, M_1^f, M_2^f, M_6^f, m_{61}^f, m_2^f, m_1^f, m_{62}^f\} \equiv \sum_{i=1}^N \int_{z_i}^{z_{i+1}} \begin{Bmatrix} \bar{\Lambda}_1^{(i)} \\ \bar{\Lambda}_2^{(i)} \\ \bar{\Lambda}_{12}^{(i)} \end{Bmatrix} [\tilde{Q}^{(i)}][S_1^{(i)}] dz,$$

$$\{\bar{m}_1^f, \bar{m}_1^f, \bar{m}_2^f, \bar{m}_2^f, \bar{m}_{62}^f, \bar{m}_{62}^f, \bar{m}_{61}^f, \bar{m}_{61}^f\} \equiv \sum_{i=1}^N \int_{z_i}^{z_{i+1}} \begin{Bmatrix} \bar{\Lambda}_1^{(i)} \\ \bar{\Lambda}_2^{(i)} \\ \bar{\Lambda}_{12}^{(i)} \end{Bmatrix} [\tilde{Q}^{(i)}][S_3^{(i)}] dz, \quad (76)$$

because all layers are subjected to thermal and/or moisture effects.

6. CONCLUDING REMARKS

We present a refined geometrically nonlinear theory for the dynamics and active control of elastic laminated plates with integrated piezoelectric actuators and sensors. The theory accounts for large rotations, continuity of the interlaminar shear stresses, elastic couplings between two transverse shear strains, a nonuniform distribution of transverse shear stresses within each layer, extensionality, the anisotropy of composite laminae and piezoelectric actuators and sensors, the dependence of the piezoelectric strain constants on the induced strains, and arbitrary orientations of the integrated actuators and sensors. The five derived nonlinear partial differential equations show that the dynamics of composite plates is characterized by elastic and geometric couplings among the two extension, one bending and two shearing motions. The theory contains, as special cases, the classical plate theory, the von Karman nonlinear plate theory, and the third-order shear-deformation theory. This model offers great flexibility in that any number of arbitrarily placed and oriented actuators in a substrate with complex elastic couplings can be modeled conveniently.

Acknowledgement—This work was supported by the Army Research Office under Grant No. DAAL03-89-K-0180 and the Center for Innovative Technology under Contract No. MAT-91-013.

REFERENCES

- Atluri, S. N. and Amos, A. K. (1988). *Large Space Structures: Dynamics and Control*. Springer, New York.
- Balachandran, B., Nayfeh, A. H., Smith, S. W. and Pappa, R. S. (1992). On identification of structures with internal resonances. AIAA Paper No. 92-0491.
- Bhimaraddi, A. and Stevens, L. K. (1984). A higher-order theory for free vibration of orthotropic, homogeneous, and laminated rectangular plates. *J. Appl. Mech.* **51**, 195–198.
- Chiarappa, D. J. and Claysmith, C. R. (1981). Deformable mirror surface control techniques. *J. Guidance Control* **4**, 27–34.
- Clark, R. L. and Fuller, C. R. (1990). An experimental study of the use of PVDF piezoelectric sensors in active structural acoustic approaches. *J. Acoust. Soc. Am.* **88**(s1), s148.
- Crawley, E. F., Warkentin, D. J. and Lazarus, K. B. (1988). Feasibility analysis of piezoelectric devices. Space Systems Laboratory, Massachusetts Institute of Technology, Cambridge, Massachusetts, Report, MIT-SSL #5-88.
- Di Sciuva, M. (1987). An improved shear deformation theory for moderately thick multilayered anisotropic shells and plates. *J. Appl. Mech.* **54**, 589–596.
- Fujino, Y., Pacheco, B. M. and Warnitchai, P. (1990). An experimental and analytical study of autoparametric resonance in a 3dof model of cable-stayed-beam. *Third Conference on Nonlinear Vibrations, Stability, and Dynamics of Structures and Mechanisms*, Blacksburg, VA.
- Im, S. and Atluri, S. N. (1989). Effects of a piezo-actuator on a finitely deformed beams subjected to general loading. *AIAA JI* **27**, 1801–1807.
- Jaffe, B., Cook, W. R. and Jaffe, H. (1971). *Piezoelectric Ceramics*. Academic Press, New York.
- Jones, R. M. (1975). *Mechanics of Composite Materials*. Scripta Book Company, Washington, DC.
- Lazarus, K. B. and Crawley, E. F. (1989). Induced strain actuation of composite plates. Massachusetts Institute of Technology, Cambridge, Massachusetts, GTL Report No. 197.
- Lee, C. K. (1990). Theory of laminated piezoelectric plates for the design of distributed sensors/actuators. Part I: Governing equations and reciprocal relationships. *J. Acoust. Soc. Am.* **87**, 1144–1158.
- Lee, C. K. and Moon, F. C. (1989). Laminated piezopolymer plates for torsion and bending sensors and actuators. *J. Acoust. Soc. Am.* **85**, 2432–2439.
- Librescu, L. and Schmidt, R. (1991). Substantiation of a shear-deformable theory of anisotropic composite laminated shells accounting for the interlaminar continuity conditions. *Int. J. Engng Sci.* **29**, 669–683.
- Pai, P. F. and Nayfeh, A. H. (1991). A nonlinear composite plate theory. *Nonlin. Dynamics* **2**, 445–477.
- Piezo Systems (1987). *Piezoelectric Motor/Actuator Kit Manual*. Piezo Electric Products, Inc., Advanced Technology Group, Cambridge, MD.

- Reddy, J. N. (1984). A simple higher-order theory for laminated composite plates. *J. Appl. Mech.* **45**, 745–752.
- Sessler, G. M. (1981). Piezoelectricity in polyvinylidene fluoride. *J. Acoust. Soc. Am.* **70**, 1596–1608.
- Tzou, H. S. and Gadre, M. (1989). Theoretical analysis of a multi-layered thin shell coupled with piezoelectric shell actuators for distributed vibration control. *J. Sound Vibr.* **132**, 433–450.
- Wang, B.-T., Fuller, C. R. and Dimitriadis, E. K. (1991). Active control of structurally radiated noise using multiple piezoelectric actuators. *AIAA JI* **29**, 1802–1809.
- Whitney, J. M. (1987). *Structural Analysis of Laminated Anisotropic Plates*. Technomic Publishing Company, Inc., PA.

APPENDIX A

The stress resultants and moments are defined as:

$$\begin{aligned} \{N_1, N_2, N_6, M_1, M_2, M_6, m_{61}, m_2, m_1, m_{62}\} \\ \equiv \sum_{i=1}^N \int_{z_i}^{z_{i+1}} \{\sigma_{11}^{(i)}, \sigma_{22}^{(i)}, \sigma_{12}^{(i)}\} [S_1^{(i)}] dz \\ = \sum_{i=1}^N \int_{z_i}^{z_{i+1}} \{\sigma_{11}^{(i)}, \sigma_{22}^{(i)}, \sigma_{12}^{(i)}, z\sigma_{11}^{(i)}, z\sigma_{22}^{(i)}, z\sigma_{12}^{(i)}, \\ \sigma_{11}^{(i)}g_{14}^{(i)} + \sigma_{12}^{(i)}g_{24}^{(i)}, \sigma_{22}^{(i)}g_{24}^{(i)} + \sigma_{12}^{(i)}g_{14}^{(i)}, \sigma_{11}^{(i)}g_{15}^{(i)} + \sigma_{12}^{(i)}g_{25}^{(i)}, \sigma_{22}^{(i)}g_{25}^{(i)} + \sigma_{12}^{(i)}g_{15}^{(i)}\} dz, \quad (A1) \end{aligned}$$

$$\begin{aligned} \{q_2, q_1\} = \sum_{i=1}^N \int_{z_i}^{z_{i+1}} \{\sigma_{23}^{(i)}, \sigma_{13}^{(i)}\} [S_2^{(i)}] dz \\ = \sum_{i=1}^N \int_{z_i}^{z_{i+1}} \{\sigma_{23}^{(i)}g_{24z}^{(i)} + \sigma_{13}^{(i)}g_{14z}^{(i)}, \sigma_{23}^{(i)}g_{25z}^{(i)} + \sigma_{13}^{(i)}g_{15z}^{(i)}\} dz, \quad (A2) \end{aligned}$$

$$\begin{aligned} \{\bar{m}_1, \bar{m}_1, \bar{m}_2, \bar{m}_2, \bar{m}_{62}, \bar{m}_{62}, \bar{m}_{61}, \bar{m}_{61}\} = \sum_{i=1}^N \int_{z_i}^{z_{i+1}} \{\sigma_{11}^{(i)}, \sigma_{22}^{(i)}, \sigma_{12}^{(i)}\} [S_3^{(i)}] dz \\ = \sum_{i=1}^N \int_{z_i}^{z_{i+1}} \{\sigma_{11}^{(i)}g_{24}^{(i)}, \sigma_{11}^{(i)}g_{25}^{(i)}, \sigma_{22}^{(i)}g_{14}^{(i)}, \sigma_{22}^{(i)}g_{15}^{(i)}, \sigma_{12}^{(i)}g_{14}^{(i)}, \sigma_{12}^{(i)}g_{15}^{(i)}, \sigma_{12}^{(i)}g_{24}^{(i)}, \sigma_{12}^{(i)}g_{25}^{(i)}\} dz. \quad (A3) \end{aligned}$$

$$\{\bar{s}_{21}, \bar{s}_{21}, \bar{s}_{22}, \bar{s}_{22}\} = \sum_{i=1}^N \int_{z_i}^{z_{i+1}} \{\sigma_{23}^{(i)}g_{14}^{(i)}, \sigma_{23}^{(i)}g_{15}^{(i)}, \sigma_{23}^{(i)}g_{24}^{(i)}, \sigma_{23}^{(i)}g_{25}^{(i)}\} dz, \quad (A4)$$

$$\{\bar{s}_{11}, \bar{s}_{11}, \bar{s}_{12}, \bar{s}_{12}\} = \sum_{i=1}^N \int_{z_i}^{z_{i+1}} \{\sigma_{13}^{(i)}g_{14}^{(i)}, \sigma_{13}^{(i)}g_{15}^{(i)}, \sigma_{13}^{(i)}g_{24}^{(i)}, \sigma_{13}^{(i)}g_{25}^{(i)}\} dz. \quad (A5)$$

where

$$[S_3^{(i)}] \equiv \begin{bmatrix} g_{24}^{(i)} & g_{25}^{(i)} & 0 & 0 & 0 & 0 & 0 & 0 \\ 0 & 0 & g_{14}^{(i)} & g_{15}^{(i)} & 0 & 0 & 0 & 0 \\ 0 & 0 & 0 & 0 & g_{14}^{(i)} & g_{15}^{(i)} & g_{24}^{(i)} & g_{25}^{(i)} \end{bmatrix}. \quad (A6)$$

We note that the stress resultants defined in eqns (A3)–(A5) are due to nonlinear effects and they only appear in nonlinear terms, as shown in eqns (46).

APPENDIX B

The inertial terms are given by:

$$A_u \equiv I_0 \ddot{u} + I_1 \ddot{T}_{31} + [(\gamma_5 I_6 + \gamma_4 I_5) T_{11}] + [(\gamma_4 I_7 + \gamma_5 I_8) T_{21}], \quad (B1)$$

$$A_v \equiv I_0 \ddot{v} + I_1 \ddot{T}_{32} + [(\gamma_5 I_6 + \gamma_4 I_5) T_{12}] + [(\gamma_4 I_7 + \gamma_5 I_8) T_{22}], \quad (B2)$$

$$A_w \equiv I_0 \ddot{w} + I_1 \ddot{T}_{33} + [(\gamma_5 I_6 + \gamma_4 I_5) T_{13}] + [(\gamma_4 I_7 + \gamma_5 I_8) T_{23}], \quad (B3)$$

$$\begin{aligned} A_{\gamma_4} \equiv I_5 (\ddot{u} T_{11} + \ddot{v} T_{12} + \ddot{w} T_{13}) + I_5 \ddot{\mathbf{i}}_3 \cdot \mathbf{i}_1 + \ddot{\gamma}_5 I_{56} + \ddot{\gamma}_4 I_{55} + (\gamma_5 I_{56} + \gamma_4 I_{55}) \ddot{\mathbf{i}}_1 \cdot \mathbf{i}_1 \\ + 2(\gamma_4 I_{57} + \gamma_5 I_{58}) \ddot{\mathbf{i}}_2 \cdot \mathbf{i}_1 + (\gamma_4 I_{57} + \gamma_5 I_{58}) \ddot{\mathbf{i}}_2 \cdot \mathbf{i}_1 \\ + I_7 (\ddot{u} T_{21} + \ddot{v} T_{22} + \ddot{w} T_{23}) + I_7 \ddot{\mathbf{i}}_3 \cdot \mathbf{i}_2 + \ddot{\gamma}_4 I_{77} + \ddot{\gamma}_5 I_{78} + (\gamma_4 I_{77} + \gamma_5 I_{78}) \ddot{\mathbf{i}}_2 \cdot \mathbf{i}_2 \\ + 2(\gamma_5 I_{67} + \gamma_4 I_{57}) \ddot{\mathbf{i}}_1 \cdot \mathbf{i}_2 + (\gamma_5 I_{67} + \gamma_4 I_{57}) \ddot{\mathbf{i}}_1 \cdot \mathbf{i}_2, \quad (B4) \end{aligned}$$

$$\begin{aligned} A_{\gamma_5} \equiv I_6 (\ddot{u} T_{11} + \ddot{v} T_{12} + \ddot{w} T_{13}) + I_6 \ddot{\mathbf{i}}_3 \cdot \mathbf{i}_1 + \ddot{\gamma}_5 I_{66} + \ddot{\gamma}_4 I_{56} + (\gamma_5 I_{66} + \gamma_4 I_{56}) \ddot{\mathbf{i}}_1 \cdot \mathbf{i}_1 \\ + 2(\gamma_4 I_{67} + \gamma_5 I_{68}) \ddot{\mathbf{i}}_2 \cdot \mathbf{i}_1 + (\gamma_4 I_{67} + \gamma_5 I_{68}) \ddot{\mathbf{i}}_2 \cdot \mathbf{i}_1 \\ + I_8 (\ddot{u} T_{21} + \ddot{v} T_{22} + \ddot{w} T_{23}) + I_8 \ddot{\mathbf{i}}_3 \cdot \mathbf{i}_2 + \ddot{\gamma}_4 I_{78} + \ddot{\gamma}_5 I_{88} + (\gamma_4 I_{78} + \gamma_5 I_{88}) \ddot{\mathbf{i}}_2 \cdot \mathbf{i}_2 \\ + 2(\gamma_5 I_{68} + \gamma_4 I_{58}) \ddot{\mathbf{i}}_1 \cdot \mathbf{i}_2 + (\gamma_5 I_{68} + \gamma_4 I_{58}) \ddot{\mathbf{i}}_1 \cdot \mathbf{i}_2, \quad (B5) \end{aligned}$$

$$\begin{aligned}
 A_{0_1} \equiv & -I_1(\ddot{u}T_{21} + \ddot{v}T_{22} + \ddot{w}T_{23}) - I_2\ddot{y}_3 \cdot \dot{\mathbf{i}}_2 - 2(\dot{\gamma}_5 I_{61} + \dot{\gamma}_4 I_{51})\dot{\mathbf{i}}_1 \cdot \dot{\mathbf{i}}_2 \\
 & - (\gamma_5 I_{61} + \gamma_4 I_{51})\ddot{\mathbf{i}}_1 \cdot \dot{\mathbf{i}}_2 - \dot{\gamma}_4 I_{71} - \dot{\gamma}_5 I_{81} - (\gamma_4 I_{71} + \gamma_5 I_{81})\ddot{\mathbf{i}}_2 \cdot \dot{\mathbf{i}}_2 \\
 & + (\gamma_4 I_7 + \gamma_5 I_8)(\ddot{u}T_{31} + \ddot{v}T_{32} + \ddot{w}T_{33}) + (\gamma_4 I_{71} + \gamma_5 I_{81})\ddot{\mathbf{i}}_3 \cdot \dot{\mathbf{i}}_3 \\
 & + 2(\dot{\gamma}_5 \dot{\gamma}_4 I_{67} + \dot{\gamma}_5 \dot{\gamma}_5 I_{68} + \dot{\gamma}_4 \dot{\gamma}_4 I_{57} + \dot{\gamma}_4 \dot{\gamma}_5 I_{58})\dot{\mathbf{i}}_1 \cdot \dot{\mathbf{i}}_3 \\
 & + (\gamma_5 \dot{\gamma}_4 I_{67} + \gamma_5 \dot{\gamma}_5 I_{68} + \gamma_4 \dot{\gamma}_4 I_{57} + \gamma_4 \dot{\gamma}_5 I_{58})\ddot{\mathbf{i}}_1 \cdot \dot{\mathbf{i}}_3 \\
 & + 2(\dot{\gamma}_4 \dot{\gamma}_4 I_{77} + \dot{\gamma}_4 \dot{\gamma}_5 I_{78} + \dot{\gamma}_5 \dot{\gamma}_4 I_{78} + \dot{\gamma}_5 \dot{\gamma}_5 I_{88})\dot{\mathbf{i}}_2 \cdot \dot{\mathbf{i}}_3 \\
 & + (\gamma_4 \dot{\gamma}_4 I_{77} + 2\dot{\gamma}_4 \dot{\gamma}_5 I_{78} + \gamma_5 \dot{\gamma}_5 I_{88})\ddot{\mathbf{i}}_2 \cdot \dot{\mathbf{i}}_3,
 \end{aligned} \tag{B6}$$

$$\begin{aligned}
 A_{0_2} \equiv & I_1(\ddot{u}T_{11} + \ddot{v}T_{12} + \ddot{w}T_{13}) + I_2\ddot{y}_3 \cdot \dot{\mathbf{i}}_1 + \dot{\gamma}_5 I_{61} + \dot{\gamma}_4 I_{51} \\
 & + (\gamma_5 I_{61} + \gamma_4 I_{51})\ddot{\mathbf{i}}_1 \cdot \dot{\mathbf{i}}_1 + 2(\dot{\gamma}_4 I_{71} + \dot{\gamma}_5 I_{81})\dot{\mathbf{i}}_2 \cdot \dot{\mathbf{i}}_1 + (\gamma_4 I_{71} + \gamma_5 I_{81})\ddot{\mathbf{i}}_2 \cdot \dot{\mathbf{i}}_1 \\
 & - (\gamma_5 I_6 + \gamma_4 I_5)(\ddot{u}T_{31} + \ddot{v}T_{32} + \ddot{w}T_{33}) - (\gamma_5 I_{61} + \gamma_4 I_{51})\ddot{\mathbf{i}}_3 \cdot \dot{\mathbf{i}}_3 \\
 & - 2(\dot{\gamma}_5 \dot{\gamma}_5 I_{66} + \dot{\gamma}_5 \dot{\gamma}_4 I_{56} + \dot{\gamma}_4 \dot{\gamma}_5 I_{56} + \dot{\gamma}_4 \dot{\gamma}_4 I_{55})\dot{\mathbf{i}}_1 \cdot \dot{\mathbf{i}}_3 \\
 & - (\gamma_5 \dot{\gamma}_5 I_{66} + 2\dot{\gamma}_5 \dot{\gamma}_4 I_{56} + \gamma_4 \dot{\gamma}_4 I_{55})\ddot{\mathbf{i}}_1 \cdot \dot{\mathbf{i}}_3 \\
 & - 2(\dot{\gamma}_4 \dot{\gamma}_5 I_{67} + \dot{\gamma}_4 \dot{\gamma}_4 I_{57} + \dot{\gamma}_5 \dot{\gamma}_5 I_{68} + \dot{\gamma}_5 \dot{\gamma}_4 I_{58})\dot{\mathbf{i}}_2 \cdot \dot{\mathbf{i}}_3 \\
 & - (\gamma_4 \dot{\gamma}_5 I_{67} + \gamma_4 \dot{\gamma}_4 I_{57} + \gamma_5 \dot{\gamma}_5 I_{68} + \gamma_5 \dot{\gamma}_4 I_{58})\ddot{\mathbf{i}}_2 \cdot \dot{\mathbf{i}}_3,
 \end{aligned} \tag{B7}$$

$$\begin{aligned}
 A_{0_3} \equiv & (\gamma_5 I_6 + \gamma_4 I_5)(\ddot{u}T_{21} + \ddot{v}T_{22} + \ddot{w}T_{23}) + (\gamma_5 I_{61} + \gamma_4 I_{51})\ddot{\mathbf{i}}_3 \cdot \dot{\mathbf{i}}_2 \\
 & + 2(\dot{\gamma}_5 \dot{\gamma}_5 I_{66} + \dot{\gamma}_5 \dot{\gamma}_4 I_{56} + \dot{\gamma}_4 \dot{\gamma}_5 I_{56} + \dot{\gamma}_4 \dot{\gamma}_4 I_{55})\dot{\mathbf{i}}_1 \cdot \dot{\mathbf{i}}_2 \\
 & + (\gamma_5 \dot{\gamma}_5 I_{66} + 2\dot{\gamma}_5 \dot{\gamma}_4 I_{56} + \gamma_4 \dot{\gamma}_4 I_{55})\ddot{\mathbf{i}}_1 \cdot \dot{\mathbf{i}}_2 \\
 & + \dot{\gamma}_4 \dot{\gamma}_5 I_{67} + \dot{\gamma}_4 \dot{\gamma}_4 I_{57} + \dot{\gamma}_5 \dot{\gamma}_5 I_{68} + \dot{\gamma}_5 \dot{\gamma}_4 I_{58} \\
 & + (\gamma_4 \dot{\gamma}_5 I_{67} + \gamma_4 \dot{\gamma}_4 I_{57} + \gamma_5 \dot{\gamma}_5 I_{68} + \gamma_5 \dot{\gamma}_4 I_{58})\ddot{\mathbf{i}}_2 \cdot \dot{\mathbf{i}}_2 \\
 & - (\gamma_4 I_7 + \gamma_5 I_8)(\ddot{u}T_{11} + \ddot{v}T_{12} + \ddot{w}T_{13}) - (\gamma_4 I_{71} + \gamma_5 I_{81})\ddot{\mathbf{i}}_3 \cdot \dot{\mathbf{i}}_1 \\
 & - \dot{\gamma}_5 \dot{\gamma}_4 I_{67} - \dot{\gamma}_5 \dot{\gamma}_5 I_{68} - \dot{\gamma}_4 \dot{\gamma}_4 I_{57} - \dot{\gamma}_4 \dot{\gamma}_5 I_{58} \\
 & - (\gamma_5 \dot{\gamma}_4 I_{67} + \gamma_5 \dot{\gamma}_5 I_{68} + \gamma_4 \dot{\gamma}_4 I_{57} + \gamma_4 \dot{\gamma}_5 I_{58})\ddot{\mathbf{i}}_1 \cdot \dot{\mathbf{i}}_1 \\
 & - 2(\dot{\gamma}_4 \dot{\gamma}_4 I_{77} + \dot{\gamma}_4 \dot{\gamma}_5 I_{78} + \dot{\gamma}_5 \dot{\gamma}_4 I_{78} + \dot{\gamma}_5 \dot{\gamma}_5 I_{88})\dot{\mathbf{i}}_2 \cdot \dot{\mathbf{i}}_1 \\
 & - (\gamma_4 \dot{\gamma}_4 I_{77} + 2\dot{\gamma}_4 \dot{\gamma}_5 I_{78} + \gamma_5 \dot{\gamma}_5 I_{88})\ddot{\mathbf{i}}_2 \cdot \dot{\mathbf{i}}_1,
 \end{aligned} \tag{B8}$$

where the inertias are defined as:

$$\begin{aligned}
 \{I_0, I_1, I_2, I_5, I_6, I_7, I_8\} & \equiv \sum_{i=1}^N \int_{z_i}^{z_{i+1}} \rho^{(i)} \{1, z, z^2, g_{14}^{(i)}, g_{15}^{(i)}, g_{24}^{(i)}, g_{25}^{(i)}\} dz, \\
 \{I_{51}, I_{61}, I_{71}, I_{81}\} & \equiv \sum_{i=1}^N \int_{z_i}^{z_{i+1}} \rho^{(i)} \{g_{14}^{(i)} z, g_{15}^{(i)} z, g_{24}^{(i)} z, g_{25}^{(i)} z\} dz, \\
 \{I_{55}, I_{56}, I_{57}, I_{58}\} & \equiv \sum_{i=1}^N \int_{z_i}^{z_{i+1}} \rho^{(i)} \{g_{14}^{(i)} g_{14}^{(i)}, g_{14}^{(i)} g_{15}^{(i)}, g_{14}^{(i)} g_{24}^{(i)}, g_{14}^{(i)} g_{25}^{(i)}\} dz, \\
 \{I_{66}, I_{67}, I_{68}, I_{77}, I_{78}, I_{88}\} & \equiv \sum_{i=1}^N \int_{z_i}^{z_{i+1}} \rho^{(i)} \{g_{15}^{(i)} g_{15}^{(i)}, g_{15}^{(i)} g_{24}^{(i)}, g_{15}^{(i)} g_{25}^{(i)}, g_{24}^{(i)} g_{24}^{(i)}, g_{24}^{(i)} g_{25}^{(i)}, g_{25}^{(i)} g_{25}^{(i)}\} dz
 \end{aligned} \tag{B9}$$

and

$$\begin{aligned}
 \dot{\mathbf{i}}_j \cdot \dot{\mathbf{i}}_k & = \dot{T}_{j1} T_{k1} + \dot{T}_{j2} T_{k2} + \dot{T}_{j3} T_{k3}, \\
 \ddot{\mathbf{i}}_j \cdot \dot{\mathbf{i}}_k & = \ddot{T}_{j1} T_{k1} + \ddot{T}_{j2} T_{k2} + \ddot{T}_{j3} T_{k3},
 \end{aligned} \tag{B10}$$

for $j, k = 1, 2, 3$. We note that, when there are no shear couplings and hence

$$g_{14}^{(i)} = g_{25}^{(i)} = 0, \quad I_5 = I_8 = I_{51} = I_{81} = I_{55} = I_{56} = I_{57} = I_{58} = I_{68} = I_{78} = I_{88} = 0.$$

To obtain the linear expressions of inertial terms, we use eqns (5), (6) and (9) and expand the transformation matrix $[T]$ as:

$$[T] = \begin{bmatrix} 1 & v_x & w_x \\ u_y & 1 & w_y \\ -w_x & -w_y & 1 \end{bmatrix}. \tag{B11}$$

Substituting eqns (B11) and (10) into eqns (B1)–(B8) yields the linear inertial terms as:

$$\begin{aligned}
 A_u &= I_0\ddot{u} - I_1\ddot{w}_x + I_6\ddot{\gamma}_5 + I_5\ddot{\gamma}_4, \\
 A_v &= I_0\ddot{v} - I_1\ddot{w}_y + I_7\ddot{\gamma}_4 + I_8\ddot{\gamma}_5, \\
 A_w &= I_0\ddot{w}, \\
 A_{\gamma_4} &= (I_{55} + I_{77})\ddot{\gamma}_4 + (I_{86} + I_{78})\ddot{\gamma}_5 + I_5\ddot{u} + I_7\ddot{v} - I_{51}\ddot{w}_x - I_{71}\ddot{w}_y, \\
 A_{\gamma_5} &= (I_{66} + I_{88})\ddot{\gamma}_5 + (I_{86} + I_{78})\ddot{\gamma}_4 + I_6\ddot{u} + I_8\ddot{v} - I_{61}\ddot{w}_x - I_{81}\ddot{w}_y, \\
 A_{\theta_1} &= I_2\ddot{w}_y - I_1\ddot{v} - I_{71}\ddot{\gamma}_4 - I_{81}\ddot{\gamma}_5, \\
 A_{\theta_2} &= -I_2\ddot{w}_x + I_1\ddot{u} + I_{61}\ddot{\gamma}_5 + I_{51}\ddot{\gamma}_4, \\
 A_{\theta_3} &= 0.
 \end{aligned}
 \tag{B12}$$